



NSF Engineering Research Center
for Computer Integrated Surgical
Systems and Technology



LABORATORY FOR
**Computational
Sensing + Robotics**
THE JOHNS HOPKINS UNIVERSITY

Calibration

Computer Integrated Surgery I
601.455/655



100 YEARS
JOHNS HOPKINS ENGINEERING

**WHITING
SCHOOL OF
ENGINEERING**
THE JOHNS HOPKINS UNIVERSITY

Russell H. Taylor
John C. Malone Professor of Computer Science,
Mech. Eng., Radiology, Surgery, & Otolaryngology Head-and Neck Surgery
Director, Laboratory for Computational Sensing and Robotics
The Johns Hopkins University
rht@jhu.edu



1

Calibration

Calibrate (*vt*) : 1. to determine the caliber of (as a thermometer tube); 2. to determine, rectify, or mark the gradations of (as a thermometer tube); 3. to standardize (as a measuring instrument) by determining the deviation from a standard so as to ascertain the proper correction factors; 4. ADJUST, TUNE

CIS I – 601.455/655 Fall 2023 Copyright R. H. Taylor

Computer Integrated Surgery 600.445/645



2

Calibration

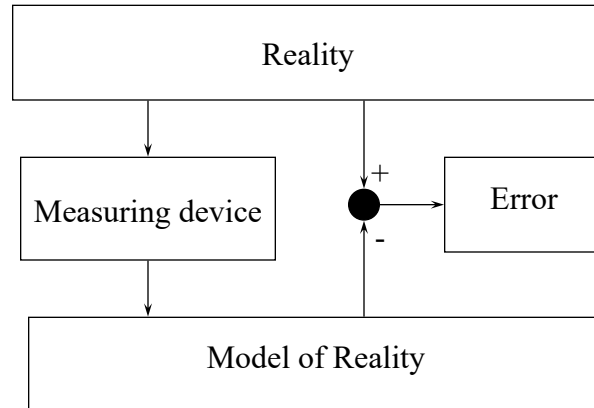

CIS I – 601.455/655 Fall 2023 Copyright R. H. Taylor

Computer Integrated Surgery 600.445/645



3

Calibration

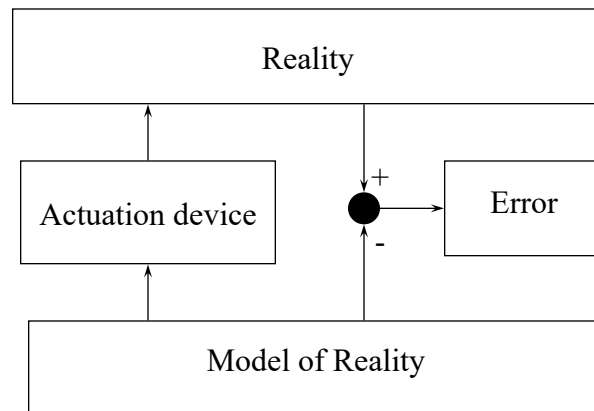

601.455/655 Copyright R. H. Taylor 1999-2021
CIS I – 601.455/655 Fall 2023 Copyright R. H. Taylor

Computer Integrated Surgery 600.445/645



4

Basic Techniques

- **Parameter Estimation**
- **Mapping the space**



5

Parameter Estimation

- Compare observed system performance to reference standard (“ground truth”)
- Compute parameters of mathematical model that minimizes residual error.

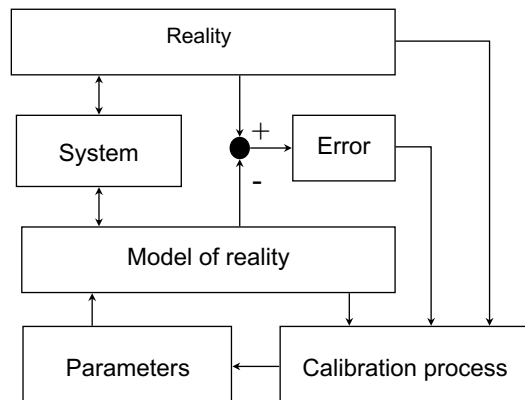

6

Pointing device calibration

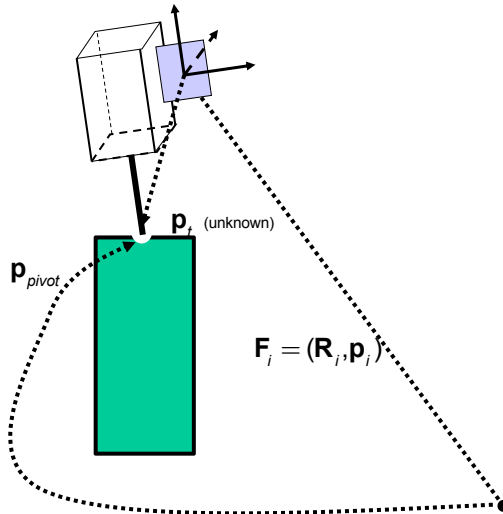

CIS I – 601.455/655 Fall 2023 Copyright R. H. Taylor

Computer Integrated Surgery 600.445/645



7

Pointing device calibration

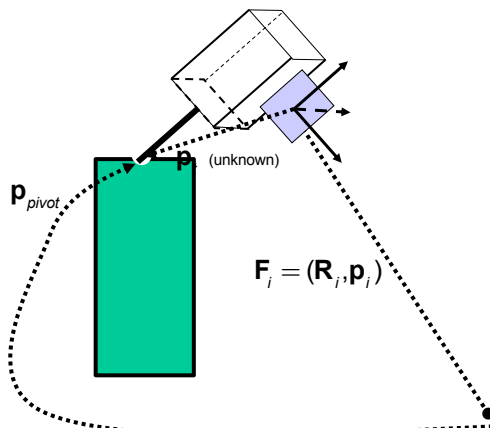

CIS I – 601.455/655 Fall 2023 Copyright R. H. Taylor

Computer Integrated Surgery 600.445/645



8

Pointing device calibration

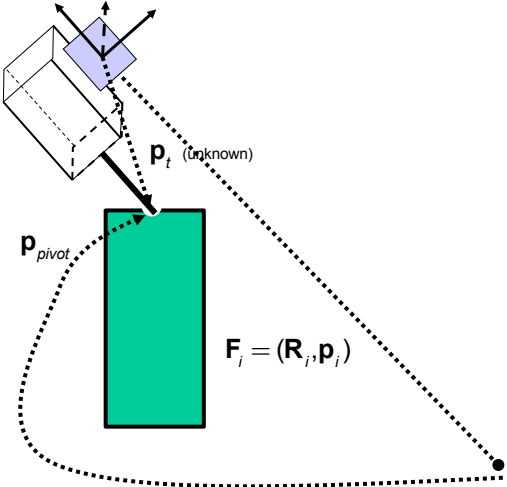

Pointing device calibration

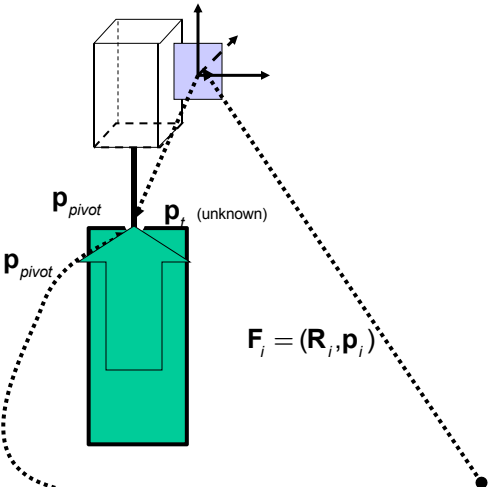

Pointing device calibration

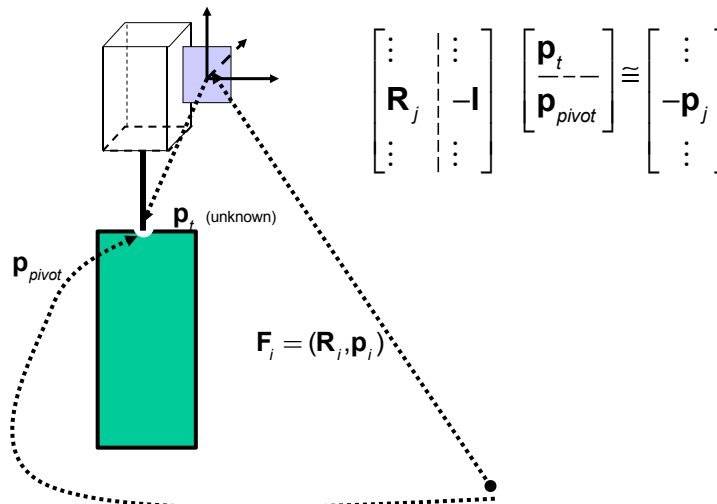

CIS I – 601.455/655 Fall 2023 Copyright R. H. Taylor

Computer Integrated Surgery 600.445/645



11

Parameter estimation

Typically, try to find the minimum of a convex function such as

$$\bar{\mathbf{q}} = \underset{\bar{\mathbf{q}}}{\operatorname{argmin}} E(\{\bar{\mathbf{f}}(\bar{\mathbf{x}}_k; \bar{\mathbf{q}}), \bar{\mathbf{p}}_k\})$$

for a function $\bar{\mathbf{f}}(\bar{\mathbf{x}}; \bar{\mathbf{q}})$ and observations $\bar{\mathbf{p}}_k = \bar{\mathbf{f}}(\bar{\mathbf{x}}_k; ?)$

There are many methods for solving this problem. You can consult any good numerical methods text, such as *Numerical Methods in C / C++ / xyz*.

Most often $E(\{\bar{\mathbf{f}}(\bar{\mathbf{x}}_k; \bar{\mathbf{q}}), \bar{\mathbf{p}}_k\})$ is a sum of squares

$$E(\{\bar{\mathbf{f}}(\bar{\mathbf{x}}_k; \bar{\mathbf{q}}), \bar{\mathbf{p}}_k\}) = \sum_k \|\bar{\mathbf{f}}(\bar{\mathbf{x}}_k; \bar{\mathbf{q}}) - \bar{\mathbf{p}}_k\|^2$$

However, other functions are also used, e.g.

$$E(\{\bar{\mathbf{f}}(\bar{\mathbf{x}}_k; \bar{\mathbf{q}}), \bar{\mathbf{p}}_k\}) = \sum_k \|\bar{\mathbf{f}}(\bar{\mathbf{x}}_k; \bar{\mathbf{q}}) - \bar{\mathbf{p}}_k\|_{L_1}$$

$$E(\{\bar{\mathbf{f}}(\bar{\mathbf{x}}_k; \bar{\mathbf{q}}), \bar{\mathbf{p}}_k\}) = \sum_k -\log(\Pr(\bar{\mathbf{f}}(\bar{\mathbf{x}}_k; \bar{\mathbf{q}}) = \bar{\mathbf{p}}_k))$$

601.455/655 Copyright R. H. Taylor 1999-2021
CIS I – 601.455/655 Fall 2023 Copyright R. H. Taylor

Computer Integrated Surgery 600.445/645



12

Linear Parameter Estimation

$\mathbf{p}_{nom} = \mathbf{f}(\mathbf{q})$ where $\mathbf{q} = [q_1, \dots, q_n]^T$ are parameters

$$\mathbf{p}^* = \mathbf{f}(\mathbf{q} + \Delta\mathbf{q})$$

$$\approx \mathbf{f}(\mathbf{q}) + \begin{bmatrix} \ddots & \vdots & & \\ \dots & \frac{\partial f_j}{\partial q_j}(\mathbf{q}) & \dots & \\ & \vdots & \ddots & \\ & & & \ddots \end{bmatrix} \begin{bmatrix} \Delta q_1 \\ \vdots \\ \Delta q_n \end{bmatrix}$$

$$\mathbf{p}^* \approx \mathbf{f}(\mathbf{q}) + \mathbf{J}_f(\mathbf{q})\Delta\mathbf{q}$$



Parameter estimation: least squares adjustment

Generally, these are iterative methods. One typical example is:

$$\bar{\mathbf{q}}^* = \operatorname{argmin}_k \sum (\bar{\mathbf{f}}(\bar{\mathbf{x}}_k; \bar{\mathbf{q}}) - \bar{\mathbf{p}}_k)^2$$

Step 0 Make an initial guess $\bar{\mathbf{q}}^{(0)}$ of the parameter vector $\bar{\mathbf{q}}$. Set $i \leftarrow 0$.

Step 1 Solve the least squares problem

$$\begin{bmatrix} \vdots \\ \mathbf{J}_f(\bar{\mathbf{q}}^{(i)}) \\ \vdots \end{bmatrix} \Delta\bar{\mathbf{q}}^{(i+1)} \equiv \begin{bmatrix} \vdots \\ \bar{\mathbf{p}}_k^* - \bar{\mathbf{f}}(\bar{\mathbf{q}}^{(i)}) \\ \vdots \end{bmatrix} \text{ to find } \Delta\bar{\mathbf{q}}^{(i+1)}$$

Step 2 $\bar{\mathbf{q}}^{(i+1)} \leftarrow \bar{\mathbf{q}}^{(i)} + \Delta\bar{\mathbf{q}}^{(i+1)}$; evaluate $\{\bar{\mathbf{e}}_k \leftarrow \bar{\mathbf{p}}_k^* - \bar{\mathbf{f}}(\bar{\mathbf{q}}^{(i+1)})\}$; $\zeta^{(i+1)} \leftarrow \sum_k \bar{\mathbf{e}}_k \cdot \bar{\mathbf{e}}_k$

Step 3 If $\zeta^{(i+1)}$ is small enough, or otherwise converged, then stop.

Else set $i \leftarrow i + 1$ and go back to Step 1.



Linear Least Squares

- Most commonly used method for parameter estimation
- Many numerical libraries
- See the web site
- Here is a quick review

[Click Here](#)

Note: There are many statistics-based methods as well. E.g., Bayesian regression, multivariate Bayesian regression



Example: 2 link robot calibration

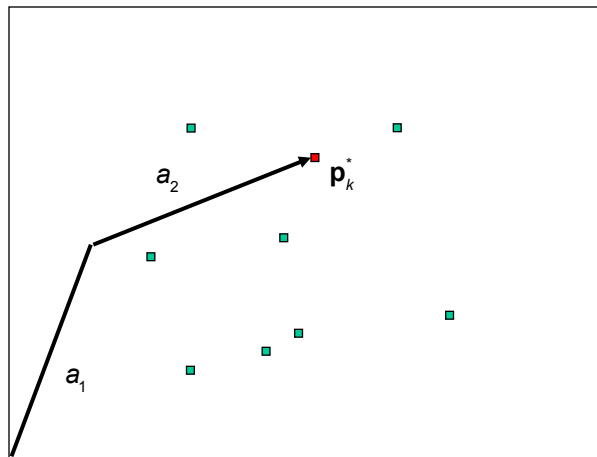

Example: 2 link robot calibration

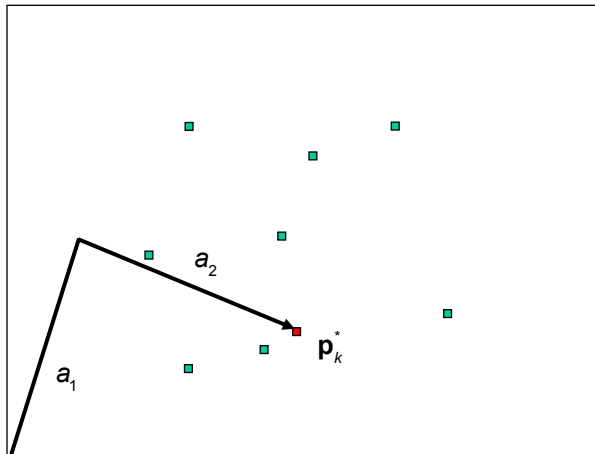

601.455/655 Copyright R. H. Taylor 1999-2021
CIS I – 601.455/655 Fall 2023 Copyright R. H. Taylor

Computer Integrated Surgery 600.445/645



17

Example: 2 link robot calibration

$$\mathbf{p} = \begin{bmatrix} a_1 \sin \theta_1 + a_2 \sin(\theta_{12}) \\ 0 \\ a_1 \cos \theta_1 + a_2 \cos(\theta_{12}) \end{bmatrix} \quad \text{where } \theta_{12} = \theta_1 + \theta_2$$

$$\mathbf{p}^* = \begin{bmatrix} (a_1 + \Delta a_1) \sin(\theta_1 + \Delta \theta_1) + (a_2 + \Delta a_2) \sin(\theta_{12} + \Delta \theta_1 + \Delta \theta_2) \\ 0 \\ (a_1 + \Delta a_1) \cos(\theta_1 + \Delta \theta_1) + (a_2 + \Delta a_2) \cos(\theta_{12} + \Delta \theta_1 + \Delta \theta_2) \end{bmatrix}$$

CIS I – 601.455/655 Fall 2023 Copyright R. H. Taylor

Computer Integrated Surgery 600.445/645



18

Example: 2 link robot calibration

$$\mathbf{p}_k = \mathbf{f}(\mathbf{q}_k) = \mathbf{f}(a_1, a_2, \theta_1, \theta_2) = \begin{bmatrix} a_1 \sin \theta_{1,k} + a_2 \sin(\theta_{12,k}) \\ 0 \\ a_1 \cos \theta_{1,k} + a_2 \cos(\theta_{12,k}) \end{bmatrix} \quad \text{where } \theta_{12} = \theta_1 + \theta_2$$

so we solve the least squares problem

$$\begin{bmatrix} \vdots & \vdots & \vdots & \vdots \\ \frac{\partial \mathbf{f}}{\partial a_1}(\mathbf{q}_k) & \frac{\partial \mathbf{f}}{\partial a_2}(\mathbf{q}_k) & \frac{\partial \mathbf{f}}{\partial \theta_1}(\mathbf{q}_k) & \frac{\partial \mathbf{f}}{\partial \theta_2}(\mathbf{q}_k) \\ \vdots & \vdots & \vdots & \vdots \end{bmatrix} \begin{bmatrix} \Delta a_1 \\ \Delta a_2 \\ \Delta \theta_1 \\ \Delta \theta_2 \end{bmatrix} \approx \mathbf{p}_k^* - \begin{bmatrix} \vdots \\ a_1 \text{Rot}(\mathbf{y}, \theta_{1,k}) \\ + a_2 \text{Rot}(\mathbf{y}, \theta_{1,k}) \\ \vdots \end{bmatrix}$$



Example: 2 link robot calibration

Here

$$J_f(\mathbf{q}_k) = \begin{bmatrix} \sin \theta_{1,k} & \sin \theta_{12,k} & a_1(\cos \theta_{1,k} + \cos \theta_{12,k}) & a_2 \cos \theta_{12,k} \\ 0 & 0 & 0 & 0 \\ \cos \theta_{1,k} & \cos \theta_{12,k} & -a_1(\sin \theta_{1,k} + \sin \theta_{12,k}) & -a_2 \cos \theta_{12,k} \end{bmatrix}$$

so

$$\begin{bmatrix} \vdots & \vdots & \vdots & \vdots \\ \sin \theta_{1,k} & \sin \theta_{12,k} & a_1(\cos \theta_{1,k} + \cos \theta_{12,k}) & a_2 \cos \theta_{12,k} \\ \cos \theta_{1,k} & \cos \theta_{12,k} & -a_1(\sin \theta_{1,k} + \sin \theta_{12,k}) & -a_2 \cos \theta_{12,k} \\ \vdots & \vdots & \vdots & \vdots \end{bmatrix} \begin{bmatrix} \Delta a_1 \\ \Delta a_2 \\ \Delta \theta_1 \\ \Delta \theta_2 \end{bmatrix} \approx \begin{bmatrix} \vdots \\ x_k^* - a_1 \sin \theta_{1,k} + a_2 \sin(\theta_{12,k}) \\ z_k^* - a_1 \cos \theta_{1,k} + a_2 \cos(\theta_{12,k}) \\ \vdots \end{bmatrix}$$



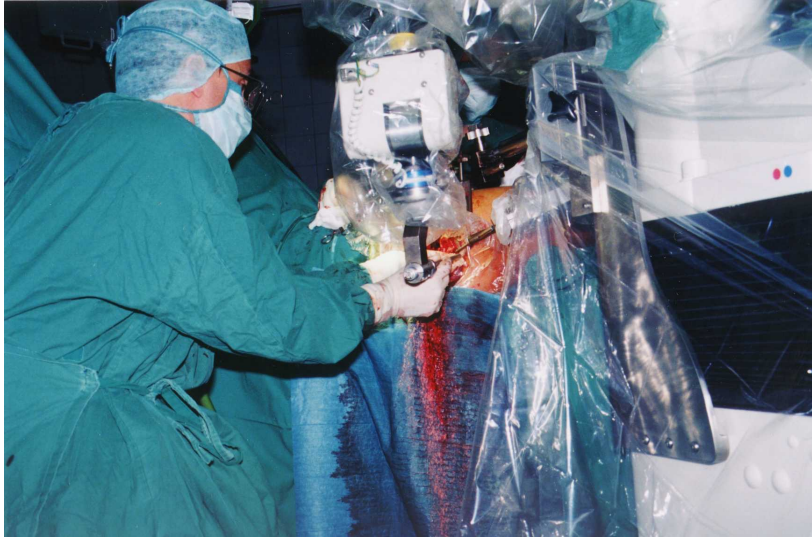

CIS I – 601.455/655 Fall 2023 Copyright R. H. Taylor

Computer Integrated Surgery 600.445/645



21

Example: Robodoc Wrist Calibration

- Basic robot in the initial IBM prototype had very accurate calibration
- Custom wrist was less accurate
- Crucial goal was to determine position of cutter tip

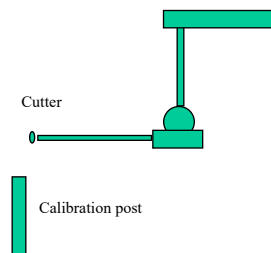

601.455/655 Copyright R. H. Taylor 1999-2021
CIS I – 601.455/655 Fall 2023 Copyright R. H. Taylor

Computer Integrated Surgery 600.445/645



22

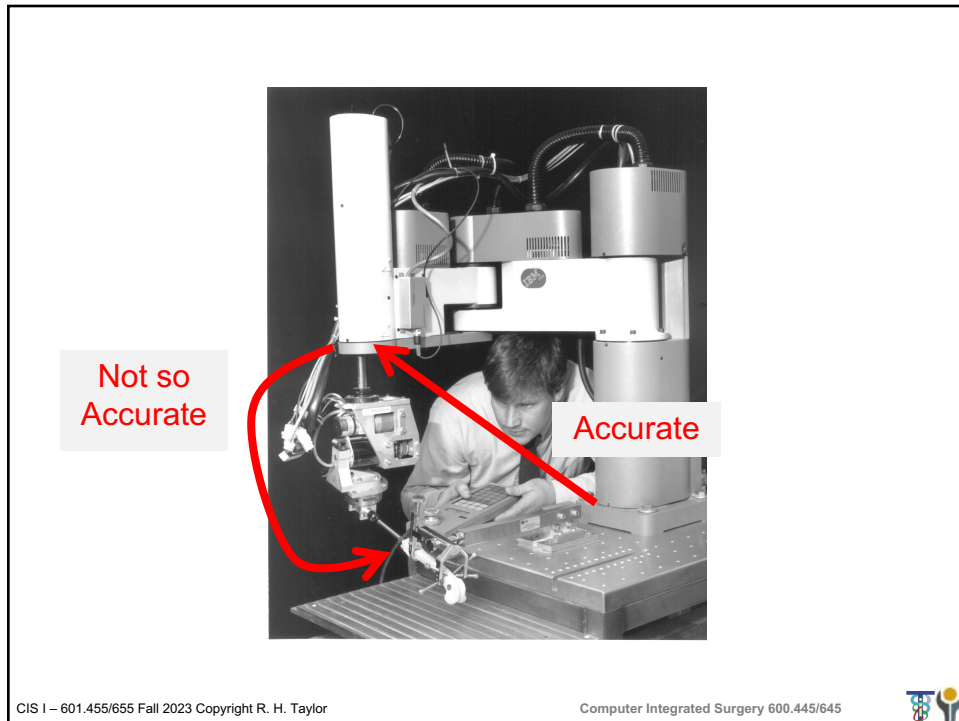

23

Kinematic Model

$$\mathbf{p}_{tool} = \mathbf{p}_{wrist} + \mathbf{R}(\mathbf{z}, \theta_4 + \Delta\theta_4) \bullet (\alpha \mathbf{x} + \mathbf{v}_{distal})$$

$$\mathbf{v}_{distal} = \mathbf{R}(\mathbf{x}, \beta) \bullet [\mathbf{R}(\mathbf{y}, \theta_5 + \Delta\theta_5)(\mathbf{v}_c + \Delta\mathbf{v}_c)]$$

CIS I – 601.455/655 Fall 2023 Copyright R. H. Taylor

Computer Integrated Surgery 600.445/645

24

Linearization

$$\mathbf{p}_{post} \approx \mathbf{p}_{wrist} + [\mathbf{R}_4 \mathbf{R}_5 (\mathbf{v}_c + \Delta \mathbf{v}_c)] + \dots$$



25

Example: Undistorted fluoroscope calibration

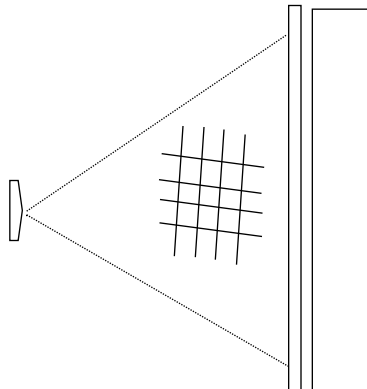

26

Calibration if no distortion (version 1)

Assume no distortion. For the moment also assume that you have N point calibration features (e.g., small steel balls) at known positions $\{\mathbf{a}_0, \dots, \mathbf{a}_{N-1}\}$ relative to the detector. Assume further that the points create images at corresponding points $\{\mathbf{d}_0, \dots, \mathbf{d}_{N-1}\}$ on the detector. Estimate the position \mathbf{s} of the x-ray source relative to the detector



27

Approach

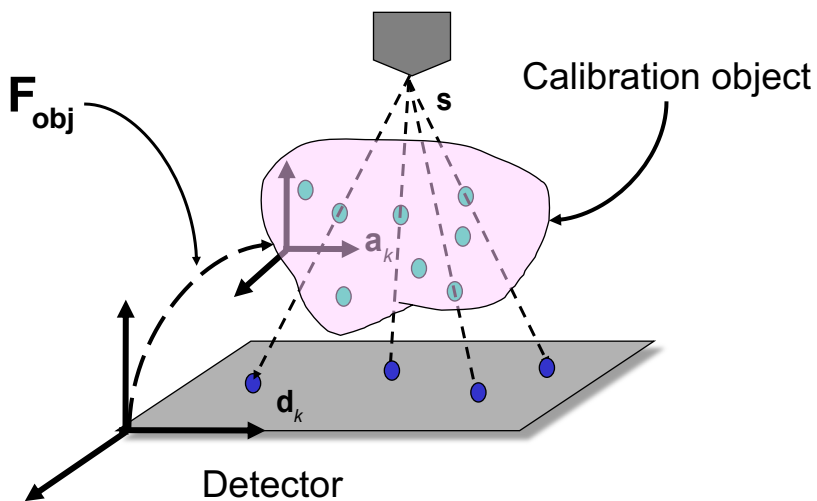

28

Projection of a point feature

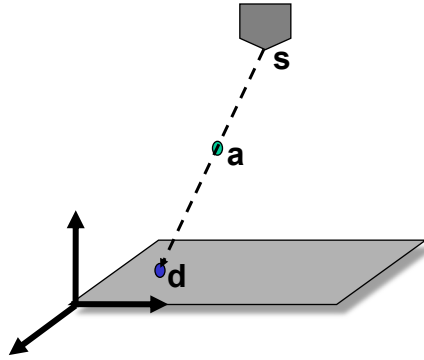

$$\mathbf{s} = \lambda(\mathbf{a} - \mathbf{d}) + \mathbf{d}$$

$$\lambda = \frac{(\mathbf{a} - \mathbf{d}) \cdot (\mathbf{s} - \mathbf{d})}{(\mathbf{a} - \mathbf{d}) \cdot (\mathbf{a} - \mathbf{d})}$$

$$\mathbf{d} = \mu(\mathbf{a} - \mathbf{s}) + \mathbf{s}$$

$$\mu = \frac{(\mathbf{a} - \mathbf{s}) \cdot (\mathbf{d} - \mathbf{s})}{(\mathbf{a} - \mathbf{s}) \cdot (\mathbf{a} - \mathbf{s})}$$

CIS I – 601.455/655 Fall 2023 Copyright R. H. Taylor

Computer Integrated Surgery 600.445/645



29

Approach

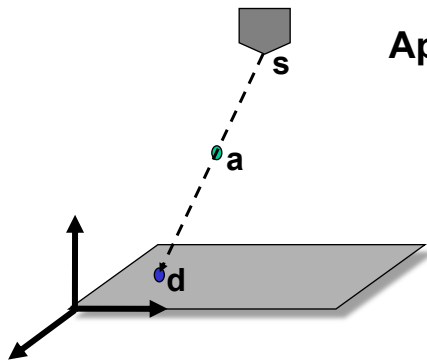

$$(\mathbf{a} - \mathbf{d}) \times (\mathbf{s} - \mathbf{d}) = \mathbf{0}$$

$$\begin{aligned} \text{skew}(\mathbf{a} - \mathbf{d}) \cdot \mathbf{s} &= (\mathbf{a} - \mathbf{d}) \times \mathbf{d} \\ &= \mathbf{a} \times \mathbf{d} - \mathbf{d} \times \mathbf{d} \\ &= \mathbf{a} \times \mathbf{d} \end{aligned}$$

$$\begin{bmatrix} 0 & d_z - a_z & a_y - d_y \\ a_z - d_z & 0 & d_x - a_x \\ d_y - a_y & a_x - d_x & 0 \end{bmatrix} \mathbf{s} = \mathbf{a} \times \mathbf{d}$$

CIS I – 601.455/655 Fall 2023 Copyright R. H. Taylor

Computer Integrated Surgery 600.445/645



30

Approach

Solve least squares problem

$$\begin{bmatrix} \text{skew}(\mathbf{a}_0 - \mathbf{d}_0) \\ \vdots \\ \text{skew}(\mathbf{a}_{N-1} - \mathbf{d}_{N-1}) \end{bmatrix} \begin{bmatrix} s_x \\ s_y \\ s_z \end{bmatrix} \equiv \begin{bmatrix} \mathbf{a}_0 \times \mathbf{d}_0 \\ \vdots \\ \mathbf{a}_{N-1} \times \mathbf{d}_{N-1} \end{bmatrix}$$

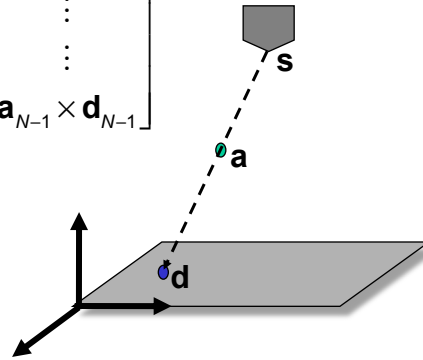

31

Typical fiducial objects

Points

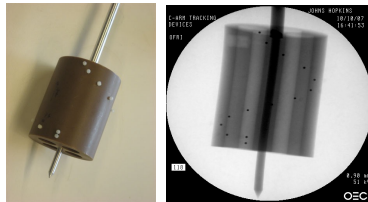

Curves

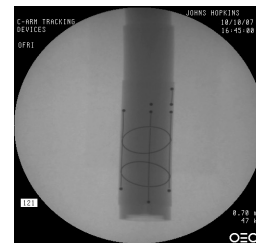
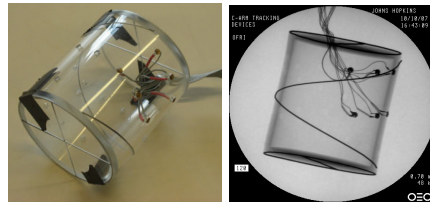

FTRAC
(Jain *et al.*)



32

What if pose of calibration object is imprecisely known?

- This is a hairier problem, but solvable
- In fact, it makes a great homework assignment



33

Calibrating trackers to robots and similar “AX = XB” problems

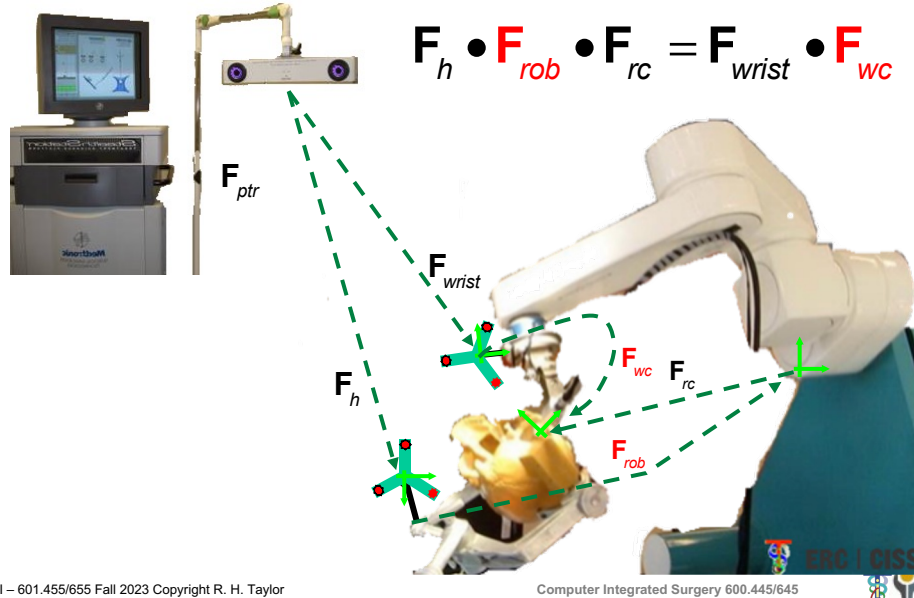

34

Problem: How do you determine

F_{rob} and F_{wc} ?

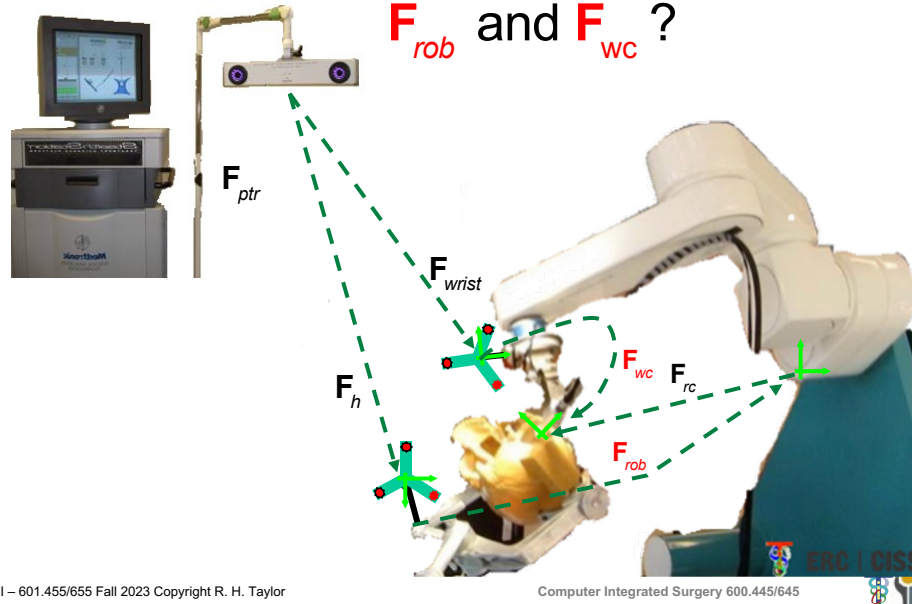

CIS I – 601.455/655 Fall 2023 Copyright R. H. Taylor

Computer Integrated Surgery 600.445/645

35

To simplify this situation, define

$$F_{hw,k} = F_{h,k}^{-1} F_{wrist,k}$$

This gives

$$F_{hc,k} = F_{hw,k} F_{wc} = F_{rob} F_{rc,k}$$

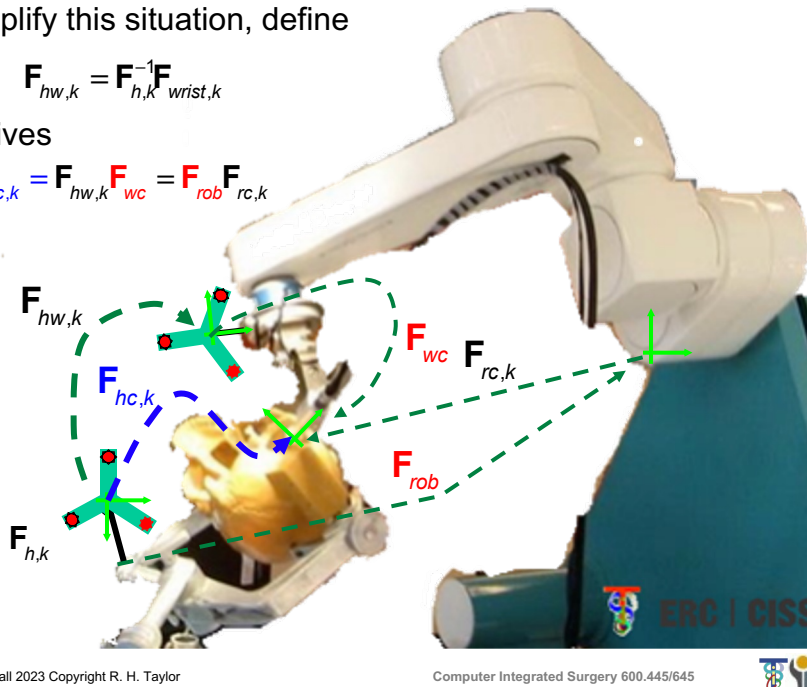

CIS I – 601.455/655 Fall 2023 Copyright R. H. Taylor

Computer Integrated Surgery 600.445/645

36

Move the robot to a sequence of poses $F_{rc,k}$ for $k = 0, \dots, N$ and observe the corresponding values of $F_{hw,k}$. Define

$$A_k = F_{hw,k} F_{hw,0}^{-1} \text{ for } k = 1, \dots, N$$

$$B_k = F_{rc,k} F_{rc,0}^{-1} \text{ for } k = 1, \dots, N$$

A_k represents motion from an initial pose
 $A_k F_{hw,0} = F_{hw,k}$
 so
 $A_k = F_{hw,k} F_{hw,0}^{-1}$
 and similarly for B_k

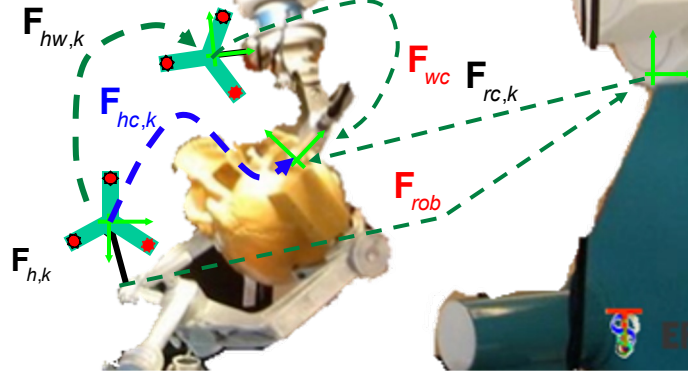

$$F_{hw,0} F_{wc} = F_{rob} F_{rc,0}$$

$$F_{wc} = F_{hw,0}^{-1} F_{rob} F_{rc,0}$$

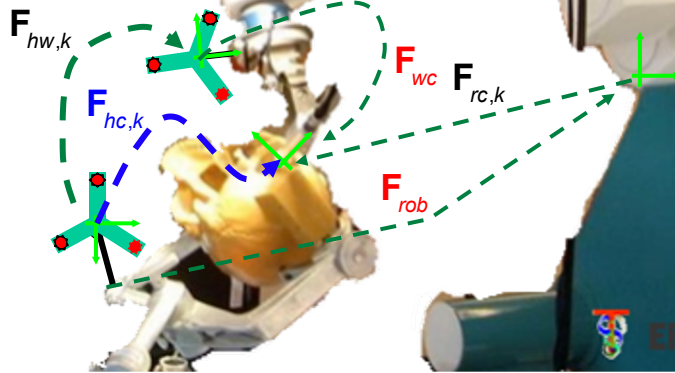

$$F_{hw,0} F_{wc} = F_{rob} F_{rc,0}$$

$$F_{wc} = F_{hw,0}^{-1} F_{rob} F_{rc,0}$$

$$F_{hw,k} F_{hw,0}^{-1} F_{rob} F_{rc,0} = F_{rob} F_{rc,k}$$

$$F_{hw,k} F_{hw,0}^{-1} F_{rob} = F_{rob} F_{rc,k} F_{rc,0}^{-1}$$

CIS I – 601.455/655 Fall 2023 Copyright R. H. Taylor

Computer Integrated Surgery 600.445/645

39

$$F_{hw,0} F_{wc} = F_{rob} F_{rc,0}$$

$$F_{wc} = F_{hw,0}^{-1} F_{rob} F_{rc,0}$$

$$F_{hw,k} F_{hw,0}^{-1} F_{rob} F_{rc,0} = F_{rob} F_{rc,k}$$

$$F_{hw,k} F_{hw,0}^{-1} F_{rob} = F_{rob} F_{rc,k} F_{rc,0}^{-1}$$

CIS I – 601.455/655 Fall 2023 Copyright R. H. Taylor

Computer Integrated Surgery 600.445/645

40

$$F_{hw,0} F_{wc} = F_{rob} F_{rc,0}$$

$$F_{wc} = F_{hw,0}^{-1} F_{rob} F_{rc,0}$$

$$F_{hw,k} F_{hw,0}^{-1} F_{rob} F_{rc,0} = F_{rob} F_{rc,k}$$

$$F_{hw,k} F_{hw,0}^{-1} F_{rob} = F_{rob} F_{rc,k} F_{rc,0}^{-1}$$

$$A_k F_{rob} = F_{rob} B_k$$

CIS I – 601.455/655 Fall 2023 Copyright R. H. Taylor

Computer Integrated Surgery 600.445/645

41

$$F_{hw,0} F_{wc} = F_{rob} F_{rc,0}$$

$$F_{wc} = F_{hw,0}^{-1} F_{rob} F_{rc,0}$$

$$F_{hw,k} F_{hw,0}^{-1} F_{rob} F_{rc,0} = F_{rob} F_{rc,k}$$

$$F_{hw,k} F_{hw,0}^{-1} F_{rob} = F_{rob} F_{rc,k} F_{rc,0}^{-1}$$

$$A_k F_{rob} = F_{rob} B_k$$

Problems of this form are often referred to as “AX=XB” problems

CIS I – 601.455/655 Fall 2023 Copyright R. H. Taylor

Computer Integrated Surgery 600.445/645

42

Exercise: Perform a similar analysis to estimate F_{wc} .

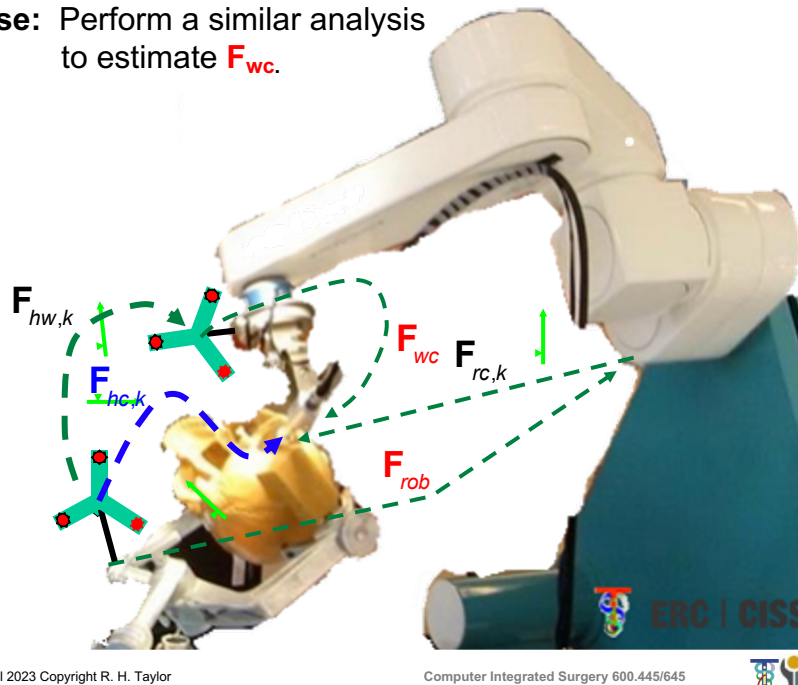

CIS I – 601.455/655 Fall 2023 Copyright R. H. Taylor

Computer Integrated Surgery 600.445/645



43

Solving “ $AX = XB$ ” problems where X is a rigid transformation

Given known frame transformations $\{F_{A,k}, F_{B,k}\}$ we want to find a best estimate $F_x = [R_x, \bar{p}_x]$ such that $F_{A,k} \bullet F_x \approx F_x \bullet F_{B,k}$.

This is equivalent to

$$R_{A,k} R_x \approx R_x R_{B,k}$$

$$R_{A,k} \bar{p}_x + \bar{p}_{A,k} \approx R_x \bar{p}_{B,k} + \bar{p}_x$$

We will solve first for the rotation part and then for the translation part.

CIS I – 601.455/655 Fall 2023 Copyright R. H. Taylor

Computer Integrated Surgery 600.445/645



45

Rotation Part (less good way)

Note: The quaternion method (discussed next) is better

We want to solve

$$\mathbf{R}_{A,k} \mathbf{R}_X \approx \mathbf{R}_X \mathbf{R}_{B,k}$$

Using the notation

$$\mathbf{R}_A = \text{Rot}(\vec{\alpha}) = \text{Rot}\left(\frac{\vec{\alpha}}{\|\vec{\alpha}\|}, \|\vec{\alpha}\|\right) = \text{Rot}(\vec{n}_A, \theta_A)$$

etc., we recall that

$$\mathbf{R}_A \mathbf{R}_X = \text{Rot}(\vec{n}_A, \theta_A) \mathbf{R}_X = \mathbf{R}_X \text{Rot}(\mathbf{R}_X^{-1} \vec{n}_A, \theta_A)$$

So

$$\mathbf{R}_X \text{Rot}(\mathbf{R}_X^{-1} \vec{n}_A, \theta_A) = \mathbf{R}_X \text{Rot}(\vec{n}_B, \theta_B)$$



Rotation Part (less good way), continued

From previous slide

$$\mathbf{R}_X \text{Rot}(\mathbf{R}_X^{-1} \vec{n}_A, \theta_A) = \mathbf{R}_X \text{Rot}(\vec{n}_B, \theta_B)$$

Multiplying both sides by \mathbf{R}_X^{-1} gives

$$\text{Rot}(\mathbf{R}_X^{-1} \vec{n}_A, \theta_A) = \text{Rot}(\vec{n}_B, \theta_B)$$

This can be expressed as

$$\mathbf{R}_X^{-1} \vec{\alpha} = \vec{\beta}$$

where $\vec{\alpha} = \theta_A \vec{n}_A$ and $\vec{\beta} = \theta_B \vec{n}_B$. Rearranging and inserting subscripts gives a system

$$\mathbf{R}_X \vec{\beta}_k = \vec{\alpha}_k$$

which can be solved for \mathbf{R}_X by standard rigid rotation estimation methods .



Rotation Part (with quaternions)

Let $\mathbf{q}_X = s_X + \vec{\mathbf{v}}_X$ be the unit quaternion corresponding to \mathbf{R}_X , with similar definitions for \mathbf{q}_A and \mathbf{q}_B . Then we have for $\mathbf{R}_A \mathbf{R}_X = \mathbf{R}_X \mathbf{R}_B$

$$\mathbf{q}_A \mathbf{q}_X = \mathbf{q}_X \mathbf{q}_B$$

Expanding the scalar and vector parts gives

$$\begin{aligned} s_A s_X - \vec{\mathbf{v}}_A \cdot \vec{\mathbf{v}}_X &= s_X s_B - \vec{\mathbf{v}}_X \cdot \vec{\mathbf{v}}_B \\ s_A \vec{\mathbf{v}}_X + s_X \vec{\mathbf{v}}_A + \vec{\mathbf{v}}_A \times \vec{\mathbf{v}}_X &= s_X \vec{\mathbf{v}}_B + s_B \vec{\mathbf{v}}_X + \vec{\mathbf{v}}_X \times \vec{\mathbf{v}}_B \end{aligned}$$

Rearranging ...

$$\begin{aligned} (s_A - s_B) s_X - (\vec{\mathbf{v}}_A - \vec{\mathbf{v}}_B) \cdot \vec{\mathbf{v}}_X &= 0 \\ (\vec{\mathbf{v}}_A - \vec{\mathbf{v}}_B) s_X + (s_A - s_B) \vec{\mathbf{v}}_X + (\vec{\mathbf{v}}_A + \vec{\mathbf{v}}_B) \times \vec{\mathbf{v}}_X &= \vec{\mathbf{0}}_3 \end{aligned}$$



Rotation Part (with quaternions, con' d)

Expressing this as a matrix equation

$$\left[\begin{array}{c|c} (s_A - s_B) & -(\vec{\mathbf{v}}_A - \vec{\mathbf{v}}_B)^T \\ \hline (\vec{\mathbf{v}}_A - \vec{\mathbf{v}}_B) & (s_A - s_B) \mathbf{I}_3 + sK((\vec{\mathbf{v}}_A + \vec{\mathbf{v}}_B)) \end{array} \right] \begin{bmatrix} s_X \\ \vec{\mathbf{v}}_X \end{bmatrix} = \begin{bmatrix} 0 \\ \vec{\mathbf{0}}_3 \end{bmatrix}$$

If we now express the quaternion \mathbf{q}_X as a 4-vector $\vec{\mathbf{q}}_X = [s_X, \vec{\mathbf{n}}_X]^T$, we can express the $\mathbf{R}_A \mathbf{R}_X = \mathbf{R}_X \mathbf{R}_B$ rotation problem as the system

$$\begin{aligned} \mathbf{M}(\mathbf{q}_A, \mathbf{q}_B) \vec{\mathbf{q}}_X &= \vec{\mathbf{0}}_4 \\ \|\vec{\mathbf{q}}_X\| &= 1 \end{aligned}$$



Rotation Part (with quaternions, con' d)

In general, we have many observations, and we want to solve the problem in a least squares sense:

$$\min \|\mathbf{M}\bar{\mathbf{q}}_x\| \text{ subject to } \|\bar{\mathbf{q}}_x\| = 1$$

where

$$\mathbf{M} = \begin{bmatrix} \mathbf{M}(\mathbf{q}_{A,1}, \mathbf{q}_{B,1}) \\ \vdots \\ \mathbf{M}(\mathbf{q}_{A,n}, \mathbf{q}_{B,n}) \end{bmatrix} \text{ and } n \text{ is the number of observations}$$

Taking the singular value decomposition of $\mathbf{M}=\mathbf{U}\Sigma\mathbf{V}^T$ reduces this to the easier problem

$$\min \|\mathbf{U}\Sigma\mathbf{V}^T\bar{\mathbf{q}}_x\| = \|\mathbf{U}(\Sigma\bar{\mathbf{y}})\| = \|\Sigma\bar{\mathbf{y}}\| \text{ subject to } \|\bar{\mathbf{y}}\| = \|\mathbf{V}^T\bar{\mathbf{q}}_x\| = \|\bar{\mathbf{q}}_x\| = 1$$



Rotation Part (with quaternions, con' d)

This problem is just

$$\min \|\Sigma\bar{\mathbf{y}}\| = \left\| \begin{bmatrix} \sigma_1 & 0 & 0 & 0 \\ 0 & \sigma_2 & 0 & 0 \\ 0 & 0 & \sigma_3 & 0 \\ 0 & 0 & 0 & \sigma_4 \end{bmatrix} \bar{\mathbf{y}} \right\| \text{ subject to } \|\bar{\mathbf{y}}\| = 1$$

where σ_i are the singular values. Recall that SVD routines return the $\sigma_i \geq 0$ and sorted in decreasing magnitude. So σ_4 is the smallest singular value and the value of $\bar{\mathbf{y}}$ with $\|\bar{\mathbf{y}}\| = 1$ that minimizes $\|\Sigma\bar{\mathbf{y}}\|$ is $\bar{\mathbf{y}} = [0, 0, 0, 1]^T$. The corresponding value of $\bar{\mathbf{q}}_x$ is given by $\bar{\mathbf{q}}_x = \mathbf{V}\bar{\mathbf{y}} = \mathbf{V}_4$. Where \mathbf{V}_4 is the 4th column of \mathbf{V} .



Displacement part

The displacement part is given by

$$\mathbf{R}_{A,k} \bar{\mathbf{p}}_X + \bar{\mathbf{p}}_{A,k} \approx \mathbf{R}_X \bar{\mathbf{p}}_{B,k} + \bar{\mathbf{p}}_X$$

Once we have solved for \mathbf{R}_X , we can rearrange the system above as

$$(\mathbf{R}_{A,k} - \mathbf{I}) \bar{\mathbf{p}}_X \approx \mathbf{R}_X \bar{\mathbf{p}}_{B,k} - \bar{\mathbf{p}}_{A,k}$$

which we can solve by least squares



52

Calibrating an Ultrasound Probe

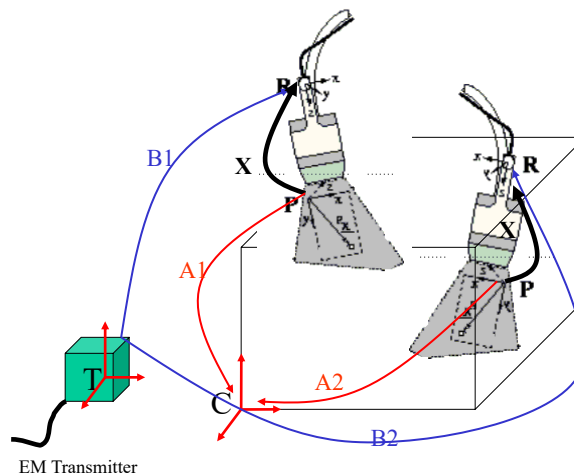

Boctor E, et. al., "A Novel Closed Form Solution For Ultrasound Calibration", ISBI 2004.



53

Mapping the space

- Compare observed system performance to reference standard (“ground truth”)
- Interpolate residual errors

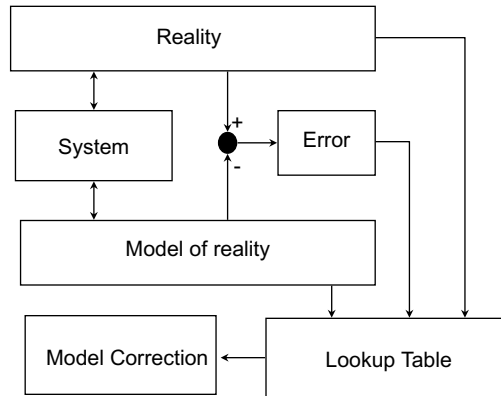

54

Example: Fluoroscope calibration

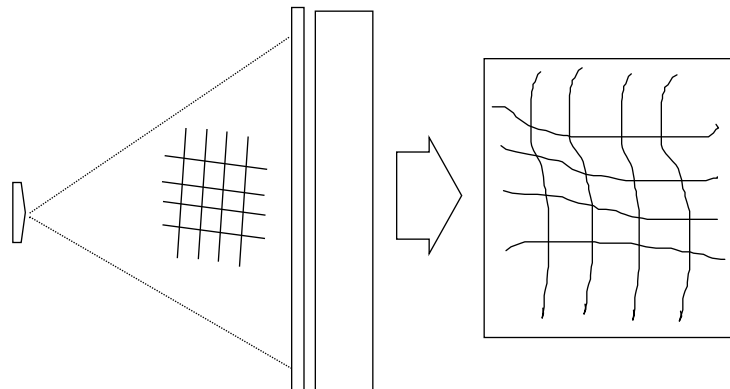

55

Projection of a point feature with distortion

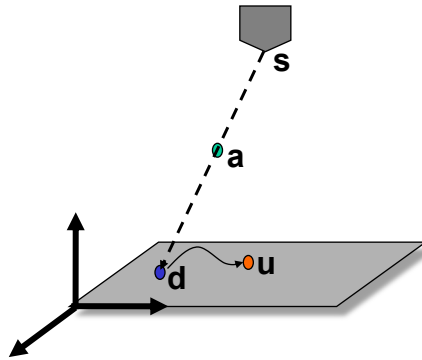

$$\mathbf{s} = \lambda(\mathbf{a} - \mathbf{d}) + \mathbf{d}$$

$$\lambda = \frac{(\mathbf{a} - \mathbf{d}) \cdot (\mathbf{s} - \mathbf{d})}{(\mathbf{a} - \mathbf{d}) \cdot (\mathbf{a} - \mathbf{d})}$$

$$\mathbf{u} = \mathbf{f}(\mathbf{d}, \bar{\nu})$$

CIS I – 601.455/655 Fall 2023 Copyright R. H. Taylor

Computer Integrated Surgery 600.445/645



56

C-arm Calibration: Motivation

- Rectify (dewarp) geometric distortions in acquired images.
- Determine the geometry of cone-beam projection
- Compute calibration for each acquired x-ray

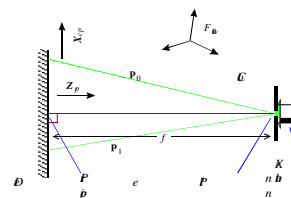
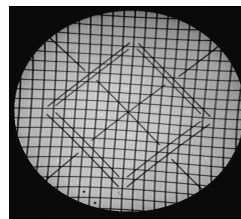

Prior studies: Boone et al., 1991; Fahrig et al., 1997; Yaniv et al., 1998; Yao, 2002; Daly et al., 2008; ...

Sadowsky, 2008

CIS I – 601.455/655 Fall 2023 Copyright R. H. Taylor

Computer Integrated Surgery 600.445/645



57

C-arm Calibration: Instruments, Methods and Results

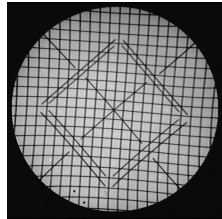

Initial x-ray of phantom

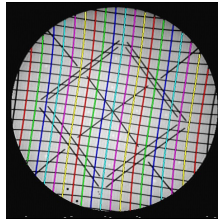

Vertical grid lines detected (horizontal follows)

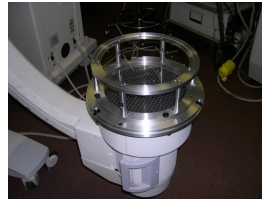

Calibration phantom mounted on image intensifier
Phantom Design: Iulian Iordachita, Ofri Sadowsky Russ Taylor

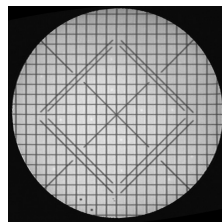

Rectified phantom image

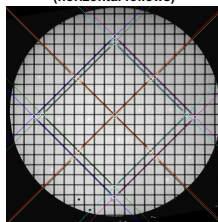

Diamond patterns detected → cone-beam parameters

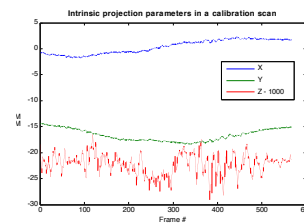

Sadowsky, 2008

Computer Integrated Surgery 600.445/645



CIS I – 601.455/655 Fall 2023 Copyright R. H. Taylor

58

Interpolation

- Ubiquitous throughout CIS research and applications
- Many techniques and methods
- Here are a few more notes

[Click here for Interpolation.ppt](#)

CIS I – 601.455/655 Fall 2023 Copyright R. H. Taylor

Computer Integrated Surgery 600.445/645



59

Dewarping Method

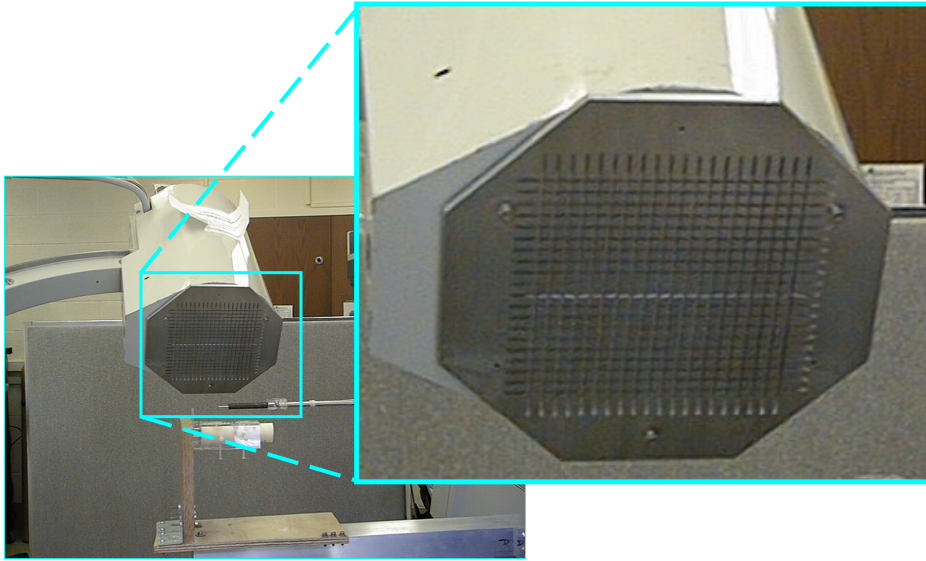

CIS I – 601.455/655 Fall 2023 Copyright R. H. Taylor

Computer Integrated Surgery 600.445/645



60

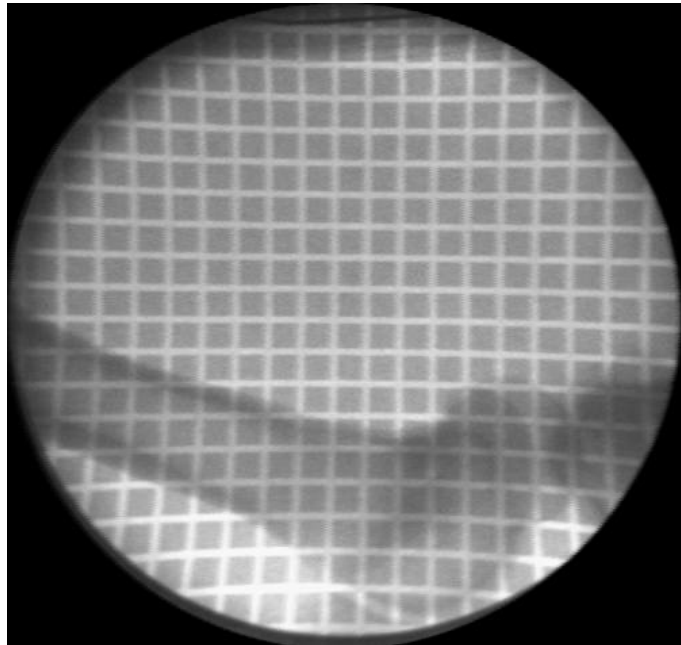

CIS I – 601.455/655 Fall 2023 Copyright R. H. Taylor

Computer Integrated Surgery 600.445/645



61

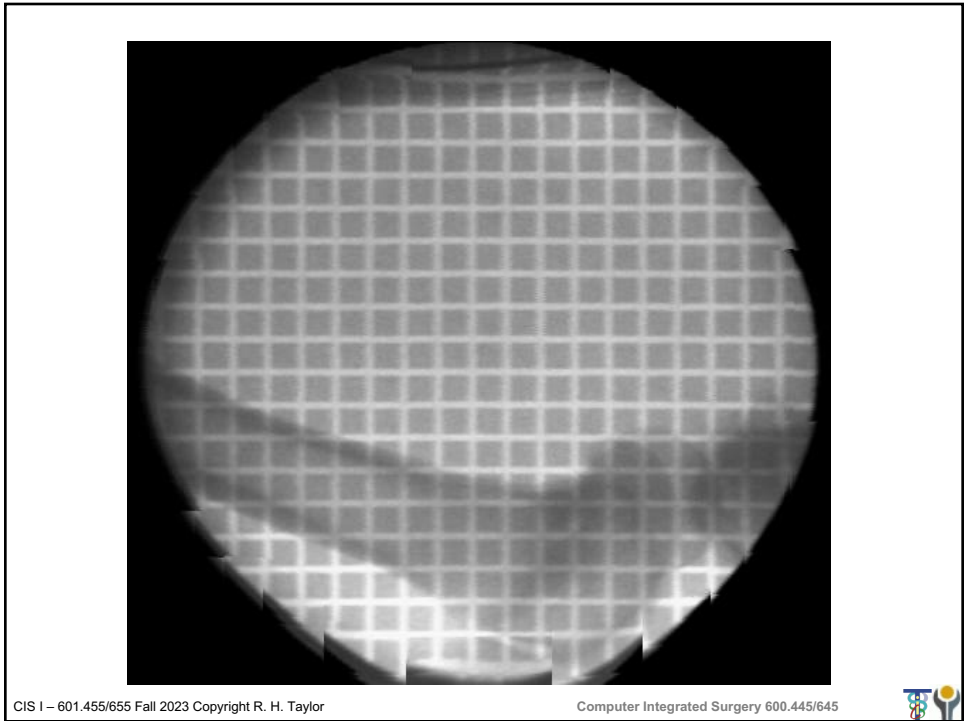

62

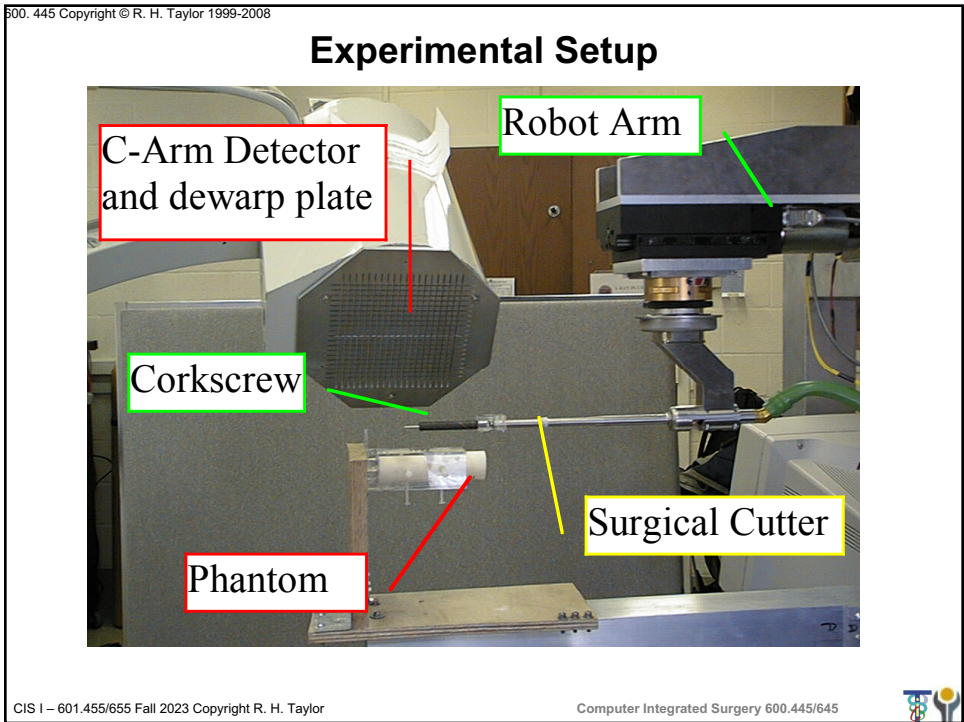

63

Dewarping Method

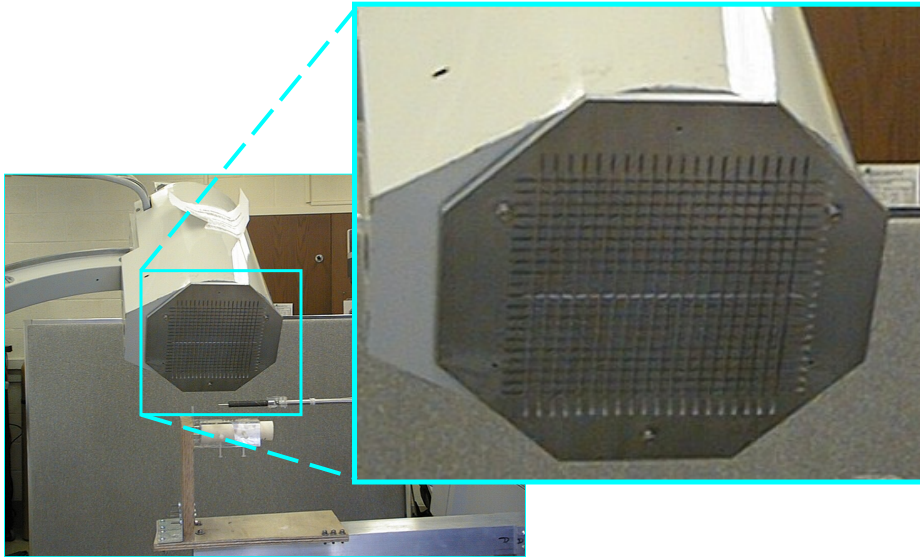

601.455/655 Copyright R. H. Taylor 1999-2021
CIS I – 601.455/655 Fall 2023 Copyright R. H. Taylor

Computer Integrated Surgery 600.445/645



64

Intrinsic Image Calibration

- Intrinsic imaging parameters (Schreiner et. al.)
- Image Warping (Checkerboard Based Method)

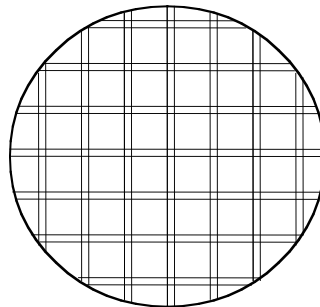

Top View

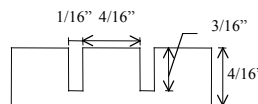

Side View

601.455/655 Copyright R. H. Taylor 1999-2021
CIS I – 601.455/655 Fall 2023 Copyright R. H. Taylor

Computer Integrated Surgery 600.445/645



65

Step 0: Acquire Image

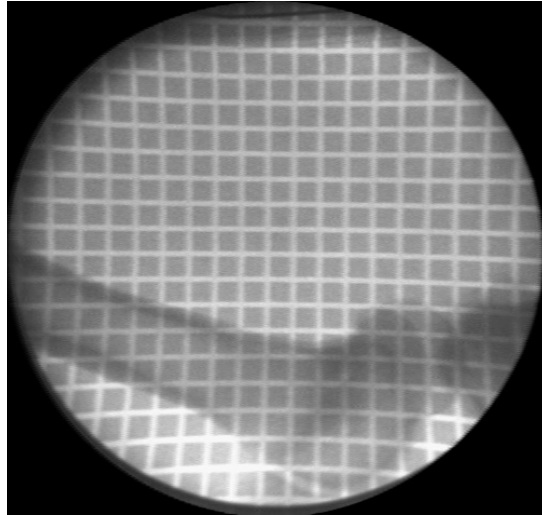

66

Step 1: Find groove points

- Find image points corresponding to the centerline of each vertical and horizontal groove

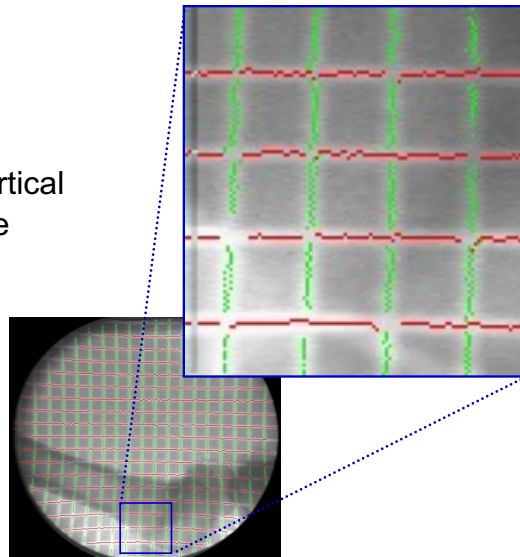

67

Step 2: Fit 5' th order Bernstein Polynomial Curves

- Fit least square smooth curve to each vertical and horizontal groove
- 5' th order Bernstein Polynomial

$$B(a_0, \dots, a_5; v) = \sum_{k=0}^5 a_k \binom{5}{k} (1-v)^{5-k} v^k$$

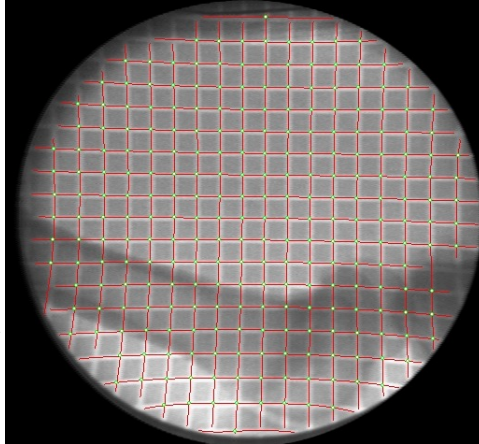

601.455/655 Copyright R. H. Taylor 1999-2021
CIS I – 601.455/655 Fall 2023 Copyright R. H. Taylor

Computer Integrated Surgery 600.445/645



68

Step 3: Dewarp

- Employ a two pass scan line algorithm to dewarp the image

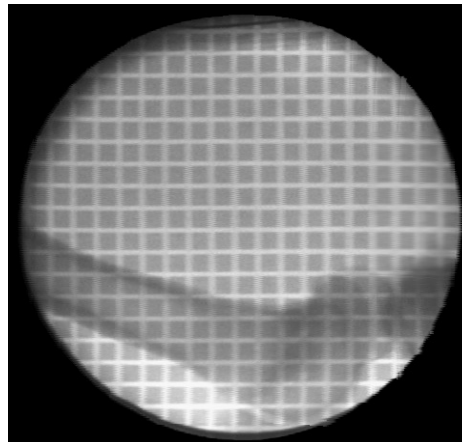

601.455/655 Copyright R. H. Taylor 1999-2021
CIS I – 601.455/655 Fall 2023 Copyright R. H. Taylor

Computer Integrated Surgery 600.445/645



69

Advantages

- **Fast**
 - *< 2 seconds on Pentium II 400*
- **Robust**
 - *works well even with overlaid objects*
- **Sub-pixel Accuracy**
 - *mean error 0.12 mm on the central area*
- **Does not completely obscure the image**
 - *trades off image contrast depth for image area*



70

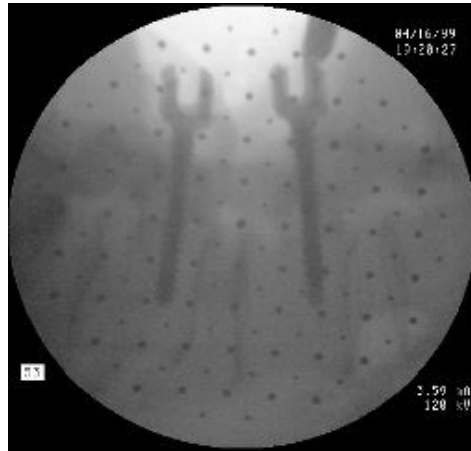
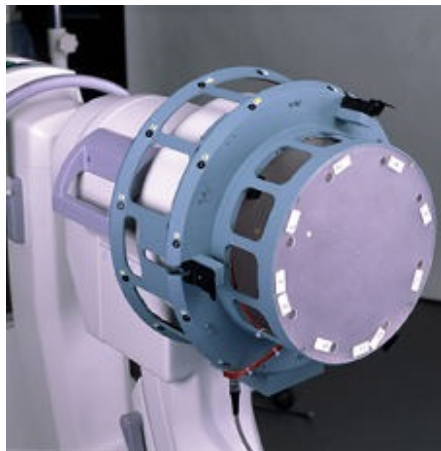

Photos: Sofamor Danek



71

Spheres i, j :
 physical location in plate = \vec{b}_{ij}
 Image location = \vec{u}_{ij}

What are the physical coordinates in the plate associated with image coordinates \vec{u}_t ?

Photos: Sofamor Danek

CIS I – 601.455/655 Fall 2023 Copyright R. H. Taylor Computer Integrated Surgery 600.445/645 

72

Two Plane Method

Plane 1 pattern Plane 2 pattern

- E.g., Lavallee
- E.g., Helm

CIS I – 601.455/655 Fall 2023 Copyright R. H. Taylor Computer Integrated Surgery 600.445/645 

73

Two Plane Method

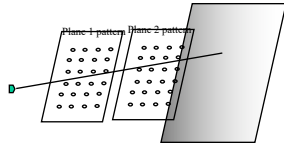

Given \mathbf{q} = a point in image coordinates,
determine the points

\mathbf{f}_1^* = the point on grid 1 corresponding to \mathbf{q}

\mathbf{f}_2^* = the point on grid 2 corresponding to \mathbf{q}

The desired ray in space passes through \mathbf{f}_1^*
and \mathbf{f}_2^* .



Two plane calibration

- Again, the essential problem is to determine the coordinates in the two planes at which the source-to-detector ray passes through the plane.
- Many methods for this. E.g.,
 - Find the four surrounding bead locations on each plane and use bilinear interpolation
 - Fit a general spline model for the distortion on each plane and then directly interpolate



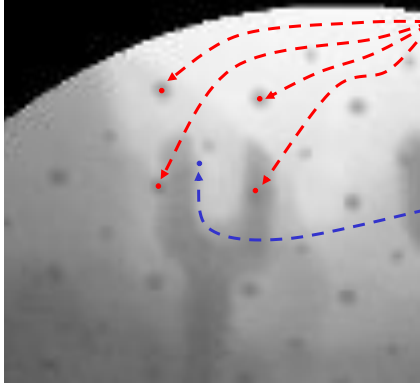

Spheres i, j :
 physical location in plate = $\vec{\mathbf{b}}_{ij}$
 Image location = $\vec{\mathbf{u}}_{ij}$

What are the physical coordinates in the plate associated with image coordinates $\vec{\mathbf{u}}_t$?

$[\lambda, \mu] \leftarrow \text{solve}(\vec{\mathbf{u}}_t = \text{bilinear}(\lambda, \mu, \{\vec{\mathbf{u}}_{ij}\}))$
 $\vec{\mathbf{b}}_t \leftarrow \text{bilinear}(\lambda, \mu, \{\vec{\mathbf{b}}_{ij}\})$

Photos: Sofamor Danek

CIS I – 601.455/655 Fall 2023 Copyright R. H. Taylor Computer Integrated Surgery 600.445/645 

76

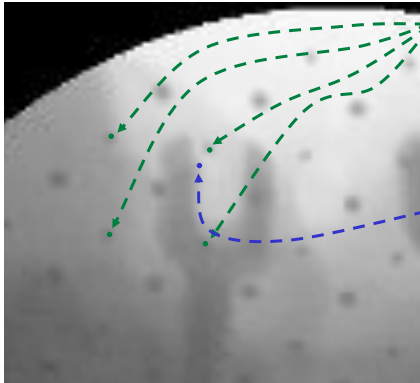

Spheres i, j :
 physical location in other plate = $\vec{\mathbf{c}}_{ij}$
 Image location = $\vec{\mathbf{u}}_{ij}^{(c)}$

What are the physical coordinates $\vec{\mathbf{c}}_t$ in the other plate associated with image coordinates $\vec{\mathbf{u}}_t$?

$[\lambda, \mu] \leftarrow \text{solve}(\vec{\mathbf{u}}_t = \text{bilinear}(\lambda, \mu, \{\vec{\mathbf{u}}_{ij}^{(c)}\}))$
 $\vec{\mathbf{c}}_t \leftarrow \text{bilinear}(\lambda, \mu, \{\vec{\mathbf{c}}_{ij}\})$

Photos: Sofamor Danek

CIS I – 601.455/655 Fall 2023 Copyright R. H. Taylor Computer Integrated Surgery 600.445/645 

77

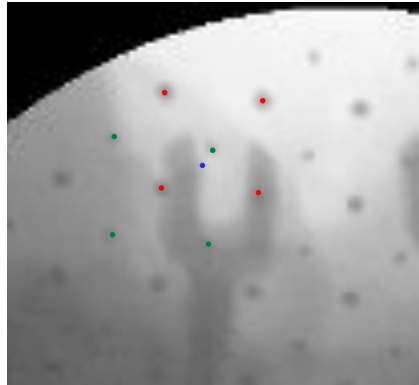

Photos: Sofamor Danek

So the points in space on the line from the x-ray source to detector corresponding to the image coordinates \vec{u}_t will be given by

$$\vec{b}_t + \gamma(\vec{c}_t - \vec{b}_t)$$

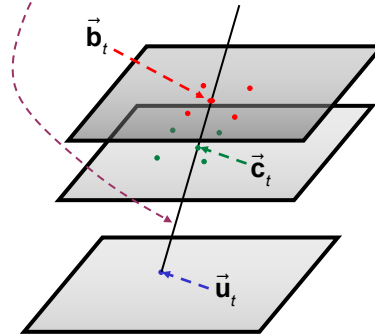

Calibration with Neural Nets

- Becoming popular in cases where unmodeled system is very complicated or ill-behaved
- Versatile
- Typically have large numbers of model parameters (weights)
- Can require extensive training data
- Training can be computationally expensive

