

Group 3: Photoacoustic System for Spinal Surgery
Team Member: Blackberrie Eddins
Mentor: Muyinatu Bell

Topic

I will be working on experiments involving a photoacoustic approach to guiding spinal surgeries. A drill prototype already exists for this application, and I will be performing experiments with the 3D printed drill bits associated with this system.

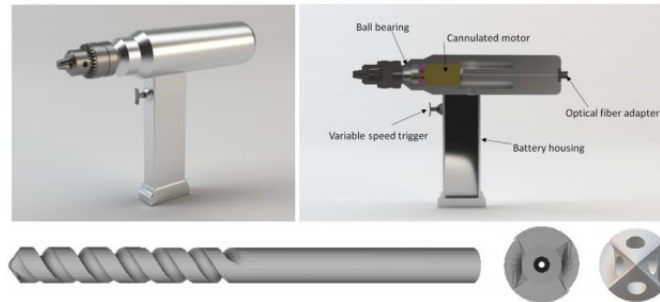

Figure 1. Drill prototype and three drill bits. Left to right: solid, single holed, and four holed tip.

Goals

I have three main goals. First, I will be doing proof of concept experiments. The previous experiments done with the photoacoustic coupled drill prototype only included imaging in water (an ideal environment) and into a dry human vertebra. I will be doing more in depth experiments, specifically with human blood, in order to show the range of structures that can be successfully imaged with our system. Second, given that the primary experiments are accomplished, I will do drill tracking experiments, with the goal of registering CT and PA coordinates. Finally, if time permits I will pursue novel image processing methods and possible ways to enhance the image signal.

Relevance/Importance

In the United States 150,000 spinal fusions are performed annually. During this procedure, pedicle screws are guided into the spine using fluoroscopic images. These images are taken using harmful radiation for both the patient and the physician, and blood vessels and nerves in the drill path cannot be visualized. Photoacoustic imaging has the potential to visualize these structures, and uses infrared light which is significantly safer on both the patient and the physician.

Technical Approach

My technical approach is segmented into three main parts: proof of concept experiments, tracking, and image analysis.

Experiments

The purpose of the experiments is to show the three drill tips inside water and obtain matched ultrasound and photoacoustic images to get a baseline. In order to collect these images I will use a phantom with blood filled tubes, and take images with and without bone. Below is a diagram of the experimental set-up. The oscilloscope generates waveforms that are sent to the laser and ultrasound system simultaneously. This couples image collection with the generation of a photoacoustic signal from the pulsed laser. The laser is coupled to the drill tip via an optical fiber, which all together creates the drill prototype. The drill prototype is used on the human bone and blood in the phantom to generate relevant surgical data. The ultrasound transducer is held against the phantom to collect the raw data. Finally, this is sent back to the ultrasound system which generates a live display of the system.

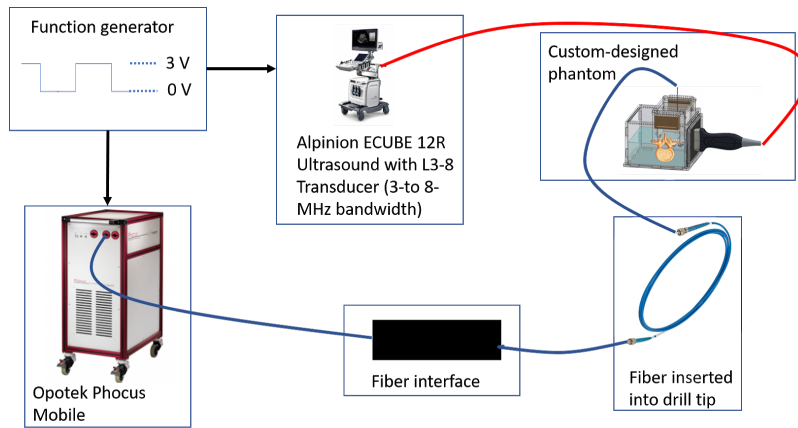

Figure 2. Experimental Technical Approach

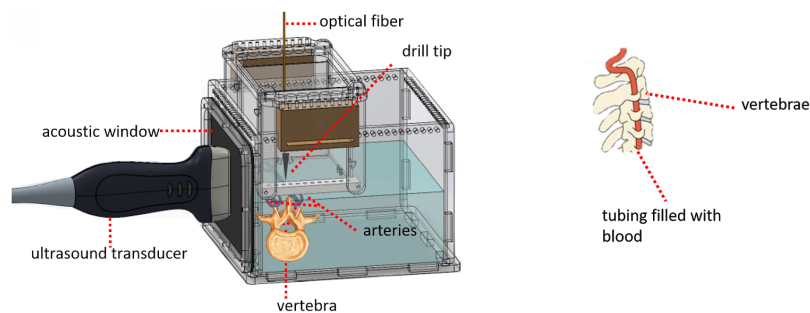

Figure 3. Phantom.

I will be testing the optical fiber in the drill tip while it is uncoupled to the drill motor to reduce bulk during experiments. Thus, just the optical fiber and drill tip are shown. The vertebra and blood-filled tubing will be placed in water to allow for signal transduction. I haven't modified the phantom yet, but I will base it off of the expected anatomy as shown. The vertebral arteries (which would be most at risk during screw insertion) run through the transverse foramen of the vertebrae, so this would be a likely tubing model. The acoustic window, made out of rubber, and the ultrasound transducer which forms the image output.

Tracking

Using the same experimental set-up as described above, I will make movie of photoacoustic images of drill bit tip moving inside the vertebra. From this video, I will extract the photoacoustic position data, and then overlay the coordinates on a CT image of the same scene using a pre-existing registration package. The CT image(s) will be acquired by someone already trained on the C-arm. The CT images will then be paired with photoacoustic images to track the drill.

Image Processing

If time permits, I will explore novel methods such as Short Lag Spatial Coherence (SLSC) Imaging in order to enhance the photoacoustic display of signals inside the spine.

Deliverables

Minimum

Visualize blood in a photoacoustic image with an optical fiber inserted into multiple drill tips.

Expected

Tracking the drill tip as it is inserted into the pre-drilled vertebra.

Maximum

Novel image processing methods to enhance photoacoustic images.

Key Dates

1. February 27: Phantom Design finished
2. March 3: begin experiments
3. March 31: finish preliminary data collection
4. April 7: begin tracking experiments
5. April 28: tracking achieved
6. May 12: finish all experiments and image processing
7. May 16: project presentation

Dependencies

The most important part of my project is the drill prototype. The drill bits have all been found and accounted for. In case something happens, I am able to re-print a piece or drill an extra bit to fit an optical fiber. To do experiments I need access to tissue samples. I have already been added to an existing IRB protocol to acquire blood samples, and the vertebra to be used in experiments is available. I have also already done bloodborne pathogen training. I will need a workspace, specifically one in a laser lab to do experiments. I already have access to Dr. Bell's lab in Barton Hall. For the tracking experiments, I will need a CT scanner. There is a C-arm in the mock OR that I should be able to use with the assistance of other students. I have not planned image acquisition with anyone, as this cannot be done until after I have completed the proof of concept experiments. In addition to access to the C-arm, I will need a pre-existing registration package to CT, as this is outside the scope of my project.

Management Plan

I have scheduled weekly meeting with Dr. Bell Friday's at 1:30 p.m. to check in on project progress as well as answer any questions that may have come up over the week. I plan to do experiments in lab on Monday and Friday evenings, or on weekends if I am not able to find time during the week.

Reading List

1. Shubert J, Bell MAL, A novel drill design for photoacoustic guided surgeries 2018
2. Reiter, A. and Bell, M. A. L., "A machine learning approach to identifying point source locations in photoacoustic data," in [Photons Plus Ultrasound: Imaging and Sensing 2017], 10064, 100643J, International Society for Optics and Photonics (2017).
3. Allman, D., Reiter, A., and Bell, M. A. L., "A machine learning method to identify and remove reflection artifacts in photoacoustic channel data," in [Ultrasonics Symposium (IUS), 2017 IEEE International], 1-4, IEEE (2017).
4. Shubert, J. and Bell, M. A. L., "Photoacoustic based visual servoing of needle tips to improve biopsy on obese patients," in [2017 IEEE International Ultrasonics Symposium (IUS)], IEEE (2017)