

# Automation of Mosquito Dissection for Malaria Vaccine Production

## Project Plan

Group 1: Henry Phalen, Michael Pozin, Alexander Cohen

Mentors: Dr. Russell Taylor, Dr. Iulian Iordachita



**Statement of Confidentiality:**



This project plan includes information, designs, and plans for items that have not been publicly disclosed due to intention of pursuing intellectual property. This document and its associated content, before that public disclosure, is only for the eyes of those who have signed a non-disclosure agreement.

**Project Goal:**

We aim to deliver a functioning mosquito dissection system that can successfully autonomously process staged mosquitoes to remove and collect their salivary glands. This dissection system will be designed to integrate as a component to a larger sporozoite-harvesting automation system, that will be used to assist in the manufacture of malaria vaccines. We intend to demonstrate the performance of our subsystem by the end of the semester.

**Background:**

A group within the Laboratory for Computational Sensing and Robotics (LCSR) at Johns Hopkins University has been working on a project in collaboration with a local company, Sanaria Inc. Sanaria has developed a method to create a malaria vaccine, something that has a tremendous potential to impact global health. This vaccine requires the injection of radiation-attenuated sporozoites of *Plasmodium falciparum* (*Pf*), the parasite that contributes to approximately 97% of the world's malaria cases [1]. These sporozoites grow within female *Anopheles* mosquitoes and humans are infected when the parasites enter their bloodstream during a bite from the mosquito. Similarly, to collect enough *Pf* sporozoites to create the vaccine, Sanaria grows mosquitoes, infects them with the parasite, and kills the mosquitoes at the correct time in the parasite's life-cycle in which a high number of these sporozoites are highly concentrated in the salivary gland of the mosquitoes (Fig. 1). At this time, technicians will manually dissect the mosquitoes under microscope with a small needle, removing the mosquito's head, and expertly squeezing the body so that the salivary gland is pushed out and can be collected [1].

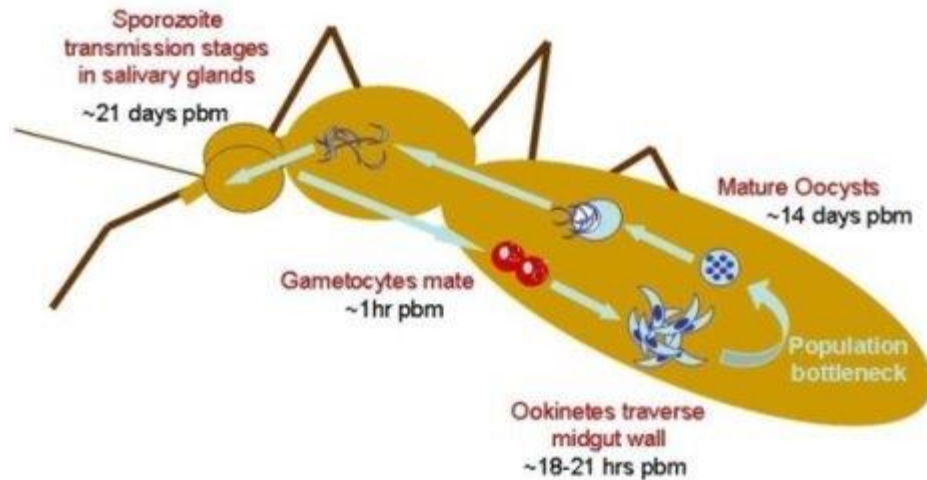

**Figure 1:** Life cycle of *Plasmodium falciparum* in female *Anopheles* mosquito. Of importance is the last stage of the cycle where the sporozoites are concentrated in the salivary glands 21 days post blood meal (pbm). Figure from [6]

This process is time-consuming and is not scalable to produce meaningful numbers of these vaccines. It can take several months for technicians to be adequately trained in this dissection process, and even then, each technician only can process about 5-6 mosquitoes per minute. These inefficiencies at scale motivated the current project in the LCSR which has a goal to create an entirely automated mosquito processing system, taking freshly killed mosquitoes in water to a collection of salivary glands. The group, in partnership with Sanaria, has received a Small Business Innovation Research (SBIR) grant from the National Institutes of Health to develop a working prototype of this system.

### **Clinical Motivation:**

Malaria presents a tremendous public health burden. The World Health Organization estimates 219 million individuals worldwide were infected with the disease in 2017 and ranked it among the top 20 leading cause of death among both adults and infants in 2016 [2,3]. While a bit harder to estimate, it is thought approximately half a million people die annually from the disease [2,4,5]. In addition to being a humanitarian crisis, both treatment, lost work, and lost life is thought to contribute to approximately \$12 billion USD of GDP loss in the continent of Africa alone [2]. Clearly, malaria is a massive problem, and for much of the world, one without a ready solution. Attempts at eradicating malaria have mostly focused on practical measures to limit exposure such as netting around bed and insecticide treatments on houses. Even these attempts have become more difficult in recent years as the parasite has adapted to show resistance to many forms of treatment. A vaccine that imbued large-scale immunity on the population would have a dramatic effect on the prevalence and spread of the disease.

### Prior Work:

An early part of the development process by the team at the LCSR was to develop an improved-efficiency manual process (or so-called “semi-automated” process) for mosquito dissection. A semi-automated mosquito micro-dissection system (sAMMS) device, depicted in Fig. 2, was developed. In this device, a technician could align many mosquitoes at once with their heads between two blades. One blade is stationary while another one is moved laterally, removing all the mosquito’s heads in one motion. Then a comb-shaped device could be pressed down to squeeze out the glands from which point they can be suctioned.

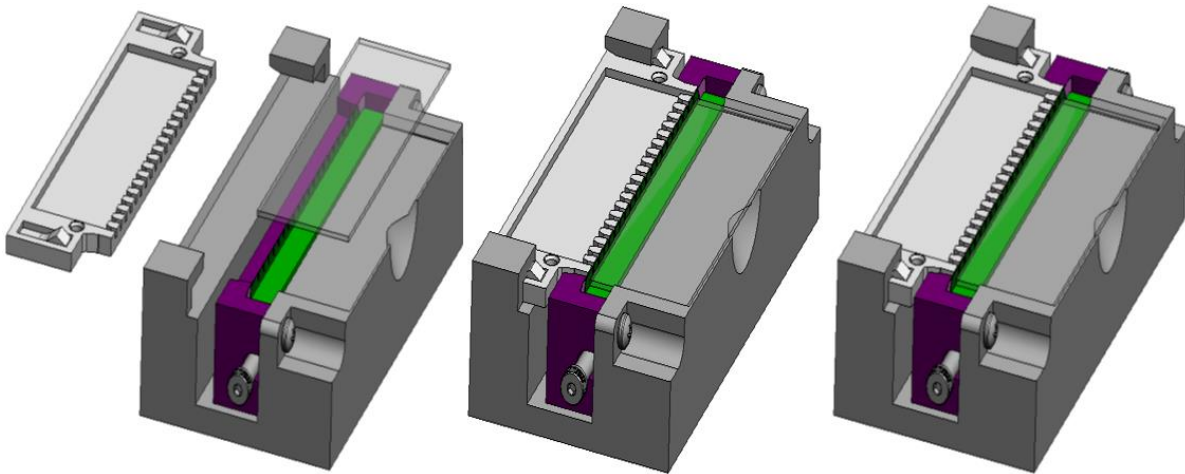

**Figure 2:** Semi-automated mosquito micro-dissection system (sAMMS) device created based off of initial prototypes from a group at LCSR. Figure from [7].

In the past year, this work has been expanded upon, with the goal to replace this manual pick-and-place task with a robot that could perform these movements. This required the design of an upstream system to stage the mosquitoes for the robot, a computer vision system to recognize the mosquitoes and provide guidance, as well as downstream processes to provide further dissection. A system overview of this system is given in Fig. 3. Specifically, our group will be responsible for continued development and integration of the robotic pick-and-place task as well as all downstream dissection processes including head removal and the squeezing out and subsequent collection of the salivary gland. We will be challenged to integrate our system with others working on other aspects of the grant, particularly an upstream mosquito staging system and computer vision.

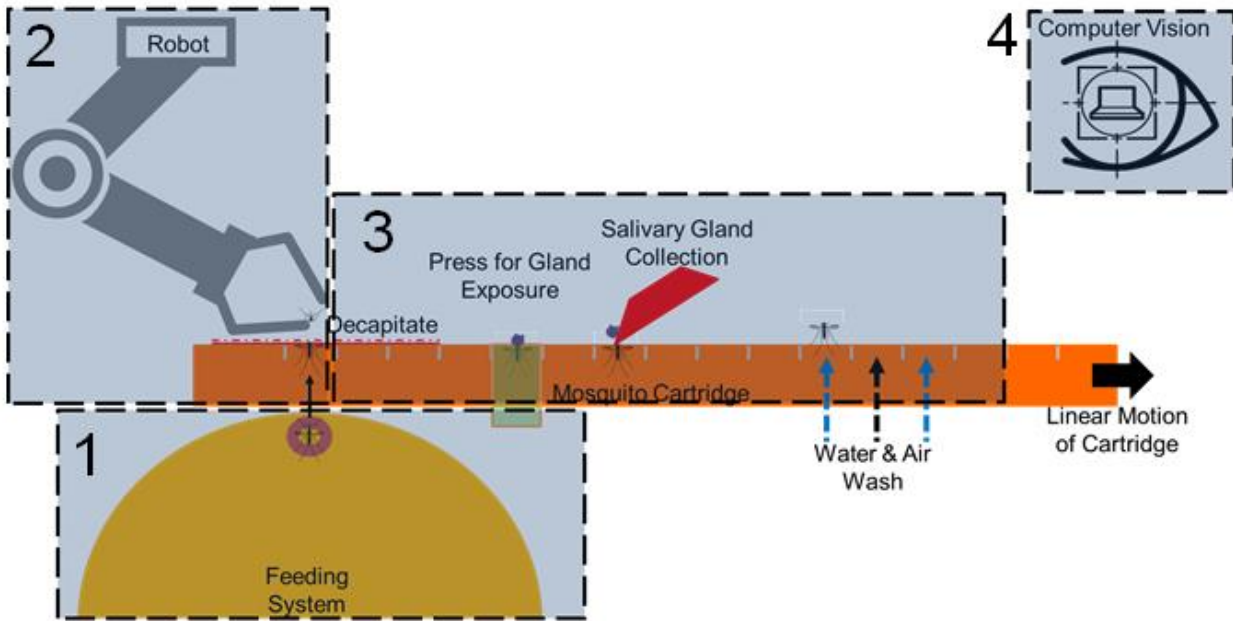

**Figure 3:** An overall system diagram describing the stages of the sporozite-harvesting system. Our mosquito dissection system represents boxes 2 and 3, robotic pick-and-place and downstream dissection, respectively. These systems will interface with a feeding or staging system for the robot and be informed by computer vision.

The robot system as it stands at the beginning stage of this project is pictured in Fig. 4 (a&b). The robot consists of a microgripper, several cameras, a cartesian stage, and a mock cartridge for testing. In particular, the current test setup utilizes a cartridge adopted from the sAMMS device outlined above. The robot is capable of picking and placing mosquitoes across the flat, white cartridge and aligning the neck of the mosquito into the designated decapitation blades. It is important to note that as the system stands, the cameras provide frames to the manual operator for click-to-actuate operation and are not yet embedded with computer vision capabilities.

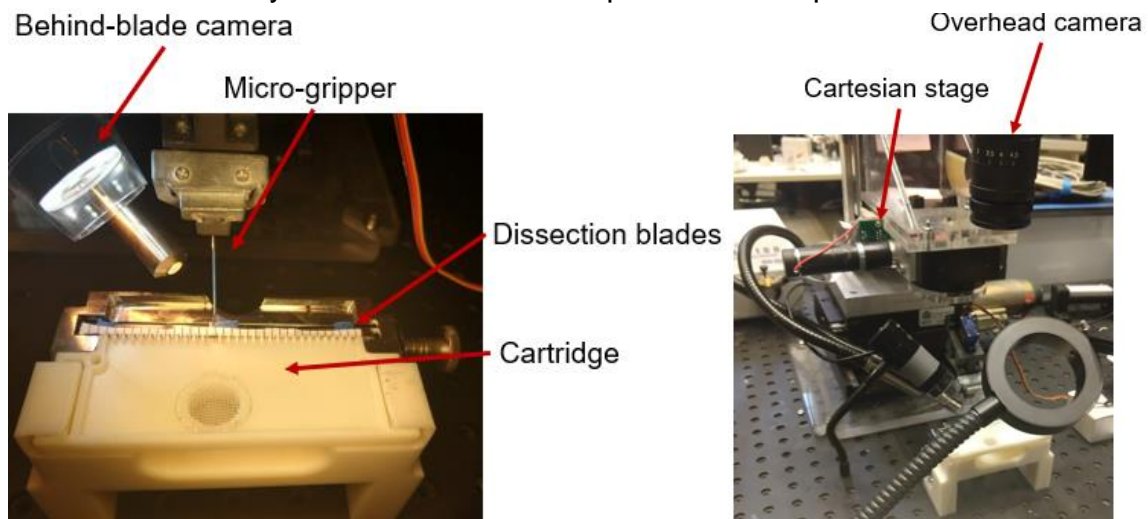

**Figure 4:** Depiction of current robot setup depicting the cartridge test assembly and micro-gripper system in figure a and the cartesian system and overhead camera assembly in figure b.

The dissection system is the other system to be developed in this project. This system consists of a linear stage lined with several modules for the rapid microdissection of mosquitoes as shown in Fig. 5. In particular, a decapitation, squeezing, gland collection, and body removal module have been proposed and implemented.

Functionality has been demonstrated in the decapitation and squeezing apparatus, but further modification will be required for improved performance of the system.

To the best of our knowledge only one group before has tried to solve the task of robotic mosquito pick-and-place before in a robotic manner and their only public results were demonstrated in 2014 [7]. We hope to provide not only a working prototype, but publishable material to further the scientific record in this area.

## **Technical Approach:**

### **1. Changes to Pick-and-Place System**

In our technical approach, we first intend to make minor changes to the robotic pick-and-place assembly such that the system is both able to better accommodate mosquitoes during processing. As it stands, we are seeing about 85% accuracy in placing mosquitoes correctly. While a positive start, we aim to be more in the neighborhood of 99%. We will be implementing several small mechanical designs to the stage on which the mosquitoes are handled, specifically hoping to reduce collisions of the mosquito body with other parts of the apparatus while the head is being placed between the blades. We believe this mechanical interference may have attributed to up to seven of the eight failures seen in a recent 50 mosquito run. We also hope to implement information from computer vision to provide mosquito-specific movements. For example, as all mosquitoes are not the same size, we may need to adjust how far we move relative to the blades to get the neck in the correct place. By integrating of movement with computer vision we can program offsets that change based on the image, providing more accurate placement.

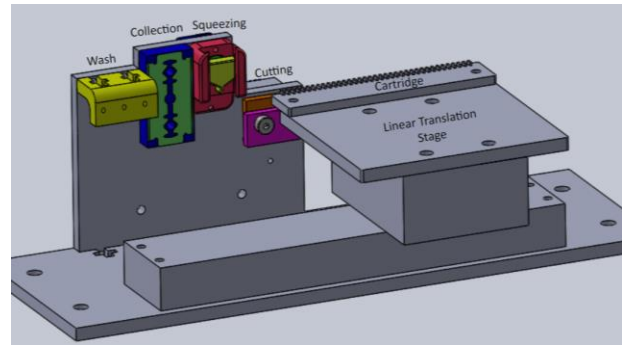

**Figure 5:** Depiction current dissection setup and more particularly the linear stage lined with a cutting, squeezing, gland collection, and wash station.



## 2. Developments and Improvements of downstream dissection

Next, we will further develop the current dissection system such that the system is capable of processing mosquitoes from placement into cartridge to gland collection. The steps required in the dissection process include: (1) decapitation, (2) squeezing, (3) gland collection, and (4) body disposal and cartridge cleanse. While the first two steps have already been rigorously tested, a redesign such that squeezing and testing can occur at the same location is required and will require additional testing. The body disposal and cartridge cleaning step will require further development. All dissection process components will require rigorous testing before they will be considered for implementation in system testing.

## 3. Multi-system integration

In order to integrate the system as a whole, we intend to develop a software platform to control the various system components. In particular, a single high-level control package is highly desirable and a single systemic timing bottleneck (likely to be robot motion) is mandatory for the success of our system. In order to accomplish this we intend to facilitate multiple system level actuation simultaneously by means of a single high-level control system which ought to communicate with several different low-level control systems. This presents a significant challenge as the different subsystems controllers operate at different frequencies and have been developed in different languages. It is important to note that we additionally plan on integrating systems developed by collaborators and are currently out of our scope of control. We anticipate that our finalized system will integrate all of the components developed by our team as well as those that become sufficiently developed by our collaborators.

## 4. Rotary Stage Design

Last, we plan to integrate a rotary stage design for cartridge motion within the dissection system. This will enable the system to function continuously in contrast to the developed linear system (which requires a “reset” motion of about 12 seconds every 36 mosquitoes processed) and reduce the dissection system bottleneck to just over a one second time during operation. Developing this rotary system will improve overall system efficiency and will utilize many of the pre-existing components from the current system.

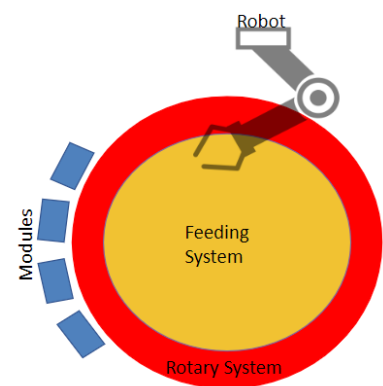

Overall, our technical approach revolves around developing our components of the system, making headway for ease of integration across multiple systems, and finally the

integration of our two subsystems (robot motion and dissection) as well as those that are ready for implementation.

### Milestones:

Physical Prototype of Gland Collection Apparatus - Expected: **03/04**

High-level Code for Robot/Dissector Integration Completed - Expected: **03/12**

Dissector Installed on Robot Setup - Expected: 03/18

**Results from Preliminary Integration Testing Completed** - Expected: **03/26**

Preliminary Testing Report - Expected: **04/01**

Implement Mechanical Changes, Finalize Rotary Design - Expected: **04/10**

Test with 100+ Mosquitoes - Expected: **04/15**

**Project Testing Report** - Expected: **04/23**

Vision System Integration - Expected: **04/29**

**Formal report Vision System Integration and Systems Level Approach** - Expected: **05/07**

### Deliverables:

<b>MIN</b>	Video of a mosquito processed from presentation to body disposal, specifically: Presentation → Pick & Place → Decapitation → Squeeze → Gland Collection → Body Disposal <b>03/26/19</b>
<b>IDEAL</b>	Written report detailing system integration (no vision), automated dissection of 50+ mosquitoes Written report of design concept of rotary stage <b>04/23/19</b>
<b>MAX</b>	Written report on system integration (with vision), automated dissection of 100+ mosquitoes Physical prototype of rotary stage concept <b>05/07/19</b>

Our minimum requirement concerns the development and improvement of an existing setup that has previously been worked on by members on this team. The system as it currently exists has several incomplete or undeveloped subsystems. To achieve this



goal, we are focused on getting the squeeze mechanism, gland collection device, and body disposal subsystems designed, implemented and tested.

Our ideal goal is threefold; written report detailing the system integration (w/o vision), automated dissection of 50+ mosquitoes, and a written report of the design of a new rotary stage concept. The written report detailing the system integration without vision, will require us to have developed the system to a point where it is processing mosquitoes. For this report we'd expect our system to be up and running to the point where it is capable of automated dissection of a minimum of 50 mosquitoes. This will give us a good idea of the viability of the system as well as shed light on any issues we find with the subsystems and will show how well the system integrates into the larger system. The report will include the results of our testing, a detailed account of the design of the system, how our system was tested, taking the form of something similar to the methods section of a standard research paper. Currently we are mainly focused on a linear stage design which has obvious downsides as compared to a rotary system when it comes to continuous dissection of mosquitoes. We plan to have developed a clear design concept of a rotary stage design which implements the subsystems for the current design with likely some small modifications.

Our maximum deliverable is like the ideal except it required us to have completed a written report detailing the system integration **with** vision, the automated dissection of 100+ mosquitoes, and a physical prototype of the rotary stage.

### Dependencies:

Dependency	Solution	Date Expected	Date Required	Mitigation
Access to shared setup, computer, robot in Robotarium	Coordinate with collaborators	2/26	2/28	Perform testing in off-hours
Access to Dr. Taylor's Lab (Alex)	Ask for Access	2/28	2/28	N/A
Access to mosquitos (weekly basis)	Email colleagues and Sanaria to coordinate pickup	Weekly	Weekly	No testing that week, or unofficial testing with old mosq's or those in ethanol
Interface with computer vision system	Rely on collaborators to continue development	3/15	4/23	Continue to use manual user-click commands
Upstream mosquito staging system	Rely on collaborators to continue development	4/1	4/23	Dissection system can be demonstrated with human-staged mosquitoes
Money for mechanical development (e.g new stage, fabrication costs, etc).	Ask mentors as needed - grant has funding	As needed	As needed	Use what resources are available
Continued functionality of recently re-designed micro gripper	Rely on collaborators to continue ongoing improvements	2/26	2/28	Complete redesign ourselves, possibly adjust project goals

## Management Plan:

As a larger team of three people, we have designated one member, Henry Phalen, as the project lead. Though all team members will be made aware of all work and strategies will be discussed on all topics at group meetings, major tasks will be distributed as follows:

- Robot control, high-level code, integration: **Henry**
- Downstream dissection: **Michael & Alex**
- 2nd generation system design: **Alex**

Several other organizational items and details are noted below:

- Group Meetings: Monday Noon - 1PM, Friday Noon - 3PM
- Weekly meetings with mentors and collaborators (Mondays 9-10AM)
- Any code stored in current project private Git repo
- Communication via Slack (Instant Messaging) and email
- All documentation stored in project JH Box and on course website

## Cited References:

- [1] Sanaria Inc. SporoBot - Build a Robot. Fight Malaria. Save Lives!, 2014. [Online]. Available: <https://www.youtube.com/watch?v=VblazNXcHFg>.
- [2] World Health Organization, *World malaria report 2018*, Nov. 2018  
<https://apps.who.int/iris/bitstream/handle/10665/275867/9789241565653-eng.pdf?ua=1>
- [3] M. P. Heron, *Deaths: Leading causes for 2016*, Centers for Disease Control National Vital Statistics Reports. 2018. [https://www.cdc.gov/nchs/data/nvsr/nvsr67/nvsr67\\_06.pdf](https://www.cdc.gov/nchs/data/nvsr/nvsr67/nvsr67_06.pdf)
- [4] Gething et al. *N Engl J Med* 375: 2435-2445, 2016.
- [5] GBD 2015 Mortality and Causes of Death Collaborators. *Lancet* 388: 1459-1544, 2016
- [6] Pollitt, Laura C., et al. "Investigating the evolution of apoptosis in malaria parasites: the importance of ecology." *Parasites & vectors* 3.1 (2010): 105.

## Reading List:

### Cited in this plan:

- [7] Mariah Schrum, Amanda Canezin, Sumana Chakravarty, Michelle Laskowski, Suat Coemert, Yunuscan Sevimli, Greg Chirikjian, Stephen L. Hoffman, and Russell H.

Taylor. "An Efficient Production Process for Extracting Salivary Glands from Mosquitoes" *Unpublished*.

Additional items:

- "Protection Against Malaria by Intravenous Immunization with a Nonreplicating Sporozoite Vaccine" Robert A. Seder, et al. *Science* 2013.
- "Protection of Humans against Malaria by Immunization with Radiation-Attenuated Plasmodium falciparum Sporozoites." Stephen L. Hoffman, et al. *Journal of Infectious Diseases* 2002.
- Richie, Thomas L., et al. "Progress with Plasmodium falciparum sporozoite (PfSPZ)-based malaria vaccines." *Vaccine* 33.52 (2015): 7452-7461.
- Phase II Mosquito Microdissection SBIR Grant Submission. Greg Chirikjian, Iulian Iordachita, Russell H. Taylor. *Unpublished & Confidential*.
- "Mosquito Staging Apparatus Design for producing PfSPZ-based Malaria Vaccines" Mengdi Xu, Shengnan Lu, Yingtian Xu, Can Kocabalkanli, Jing Jia, Brian Chirikjian, John Chirikjian, Joshua Davis, Jin Seob Kim, Sumana Chakravarty, Iulian Iordachita, Russell Taylor, Gregory Chirikjian. *Unpublished & Confidential*.