

Project 17: Actuation Design for Loop Snare Operation in Eye Surgery

Checkpoint Presentation

WENPENG WANG

MENTORS: DAVID USEVITCH, DR. ARMAND

Eye Drug Delivery

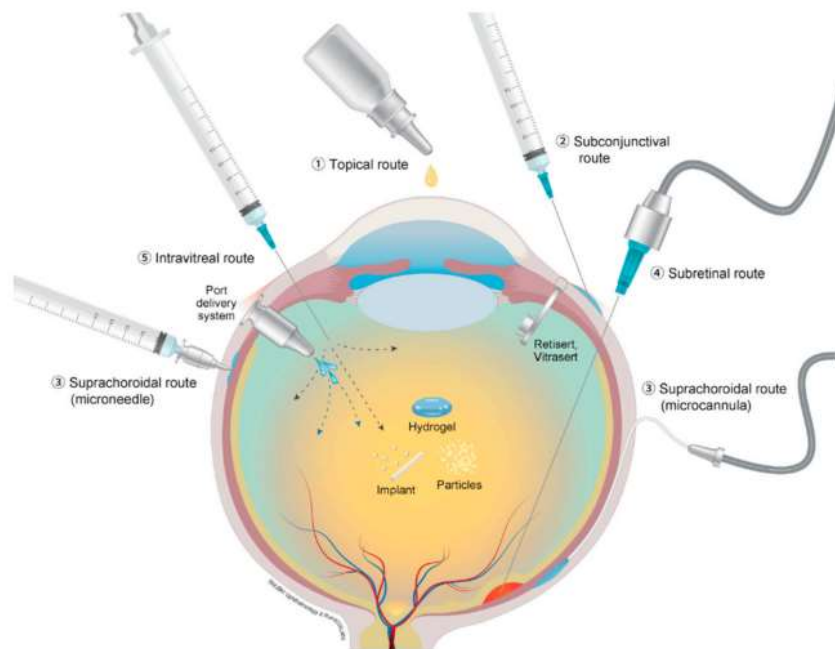

Figure 1. Schematic of several ocular drug administration routes: (1) topical route, (2) subconjunctival route, (3) suprachoroidal route with microcannula and microneedle, (4) subretinal route, and (5) intravitreal injection and port delivery system.

- This figure shows the current drug delivery methods.
- Current methods do not include a way to efficient way to delivery medicine to the backside of retina.



The problem that needs to be solved by the finished drug delivery snare loop robot.

CIS II Project Goal

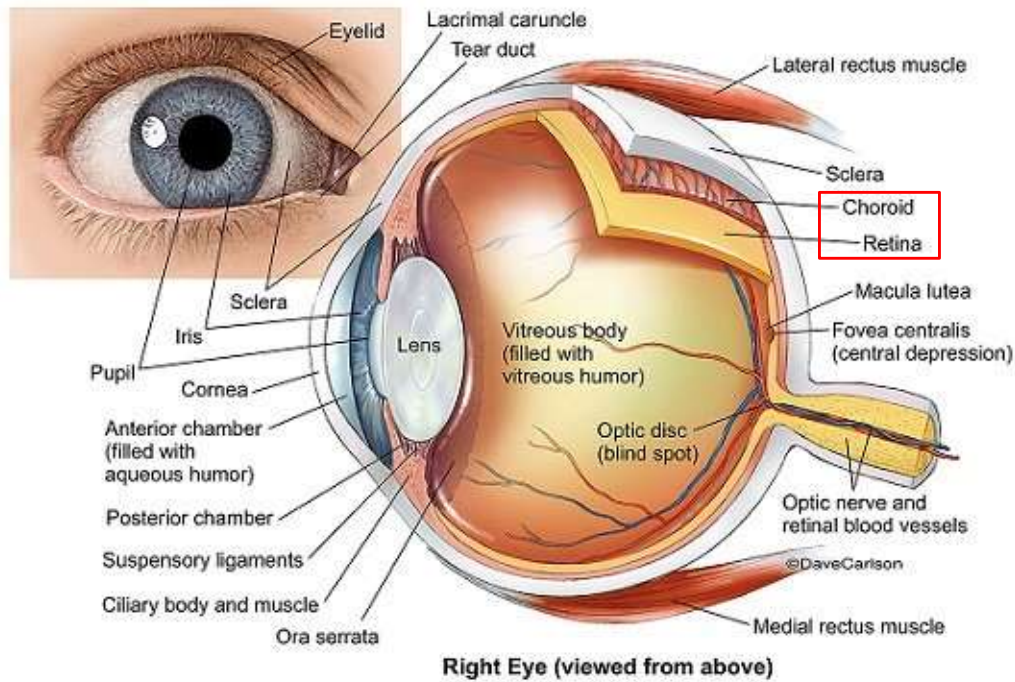

Develop actuation system housing and control method that can bend the snare loop to the desired curvature which can be used to perform drug delivery jobs:

Between Retina and Choroid

Works Done (CADs)

The following figures are for the next level prototype mainly be the expected prototype.

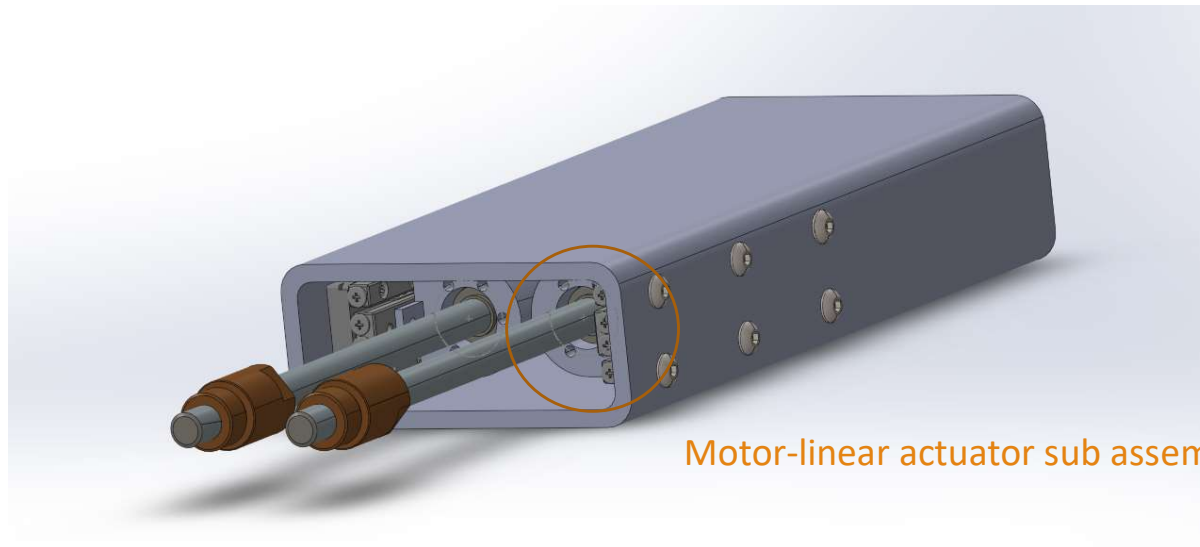

Motor-linear actuator sub assembly

Works Done (CADs)

The following figures are for the next level prototype mainly be the expected prototype.

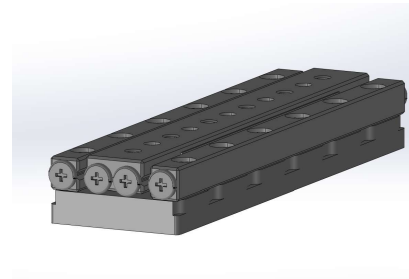
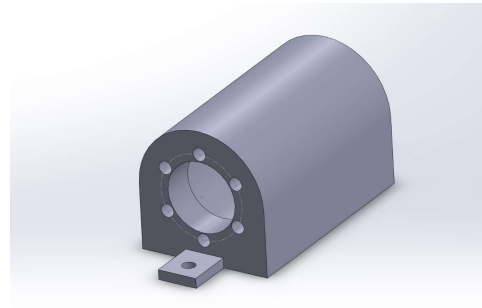
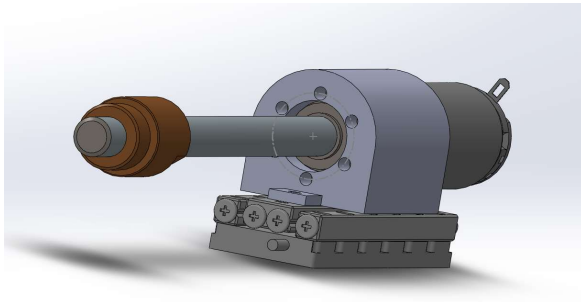

Linear actuator here is: SLC-1760 Linear Piezo Stage

Works Done (Control)

- Working python package for connecting and controlling EPOS controller

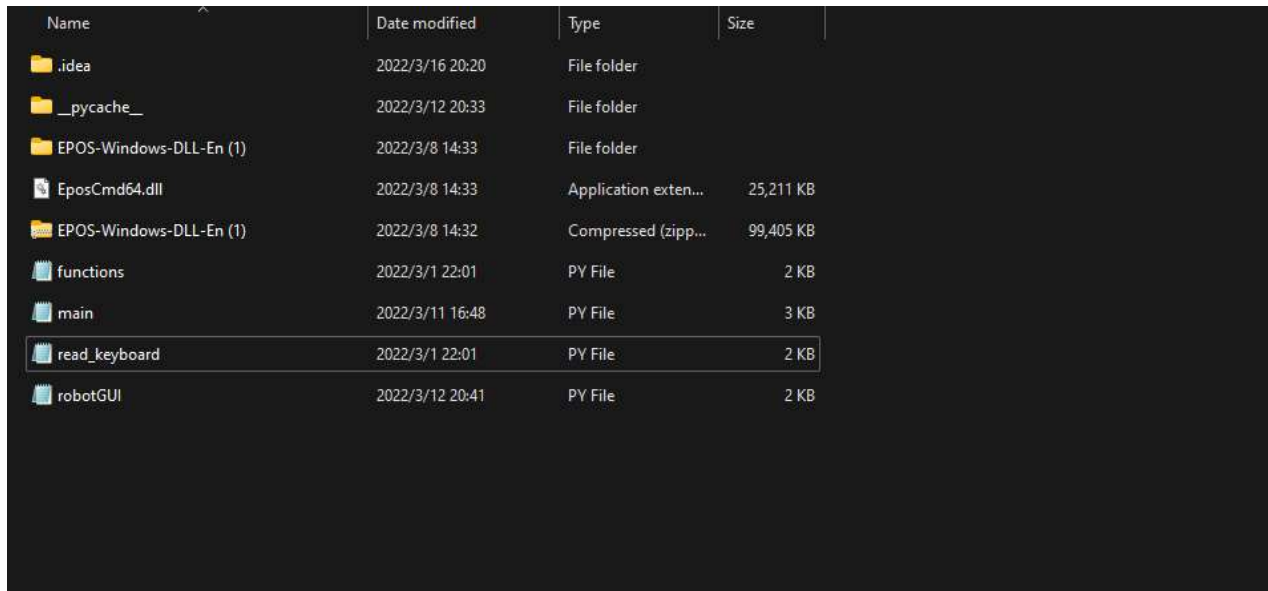

Name	Date modified	Type	Size
.idea	2022/3/16 20:20	File folder	
__pycache__	2022/3/12 20:33	File folder	
EPOS-Windows-DLL-En (1)	2022/3/8 14:33	File folder	
EposCmd64.dll	2022/3/8 14:33	Application exten...	25,211 KB
EPOS-Windows-DLL-En (1)	2022/3/8 14:32	Compressed (zipp...	99,405 KB
functions	2022/3/1 22:01	PY File	2 KB
main	2022/3/11 16:48	PY File	3 KB
read_keyboard	2022/3/1 22:01	PY File	2 KB
robotGUI	2022/3/12 20:41	PY File	2 KB

Works Done (Control)

- Simple python-based GUI with buttons, which can be used to control motors and linear actuators.



```
robotGUI x
"C:\Users\transferRNA\anaconda3\envs\Snare Py Package\python.exe" "C:/Users/transfer
loop up...
stop up...
loop up...
```

- Read the state while the button is pressed
- UP & DOWN will command the motors
- LEFT & RIGHT are platforms to connect with the control logic of linear actuators

Problems

- Can created package control 2 controller at the same time?
- Linear actuator might need a separate controller
- Control package of linear actuator in python
- GUI with readings from EPOS controller
- GUI graphic abilities based on those reading

Dependencies Updates

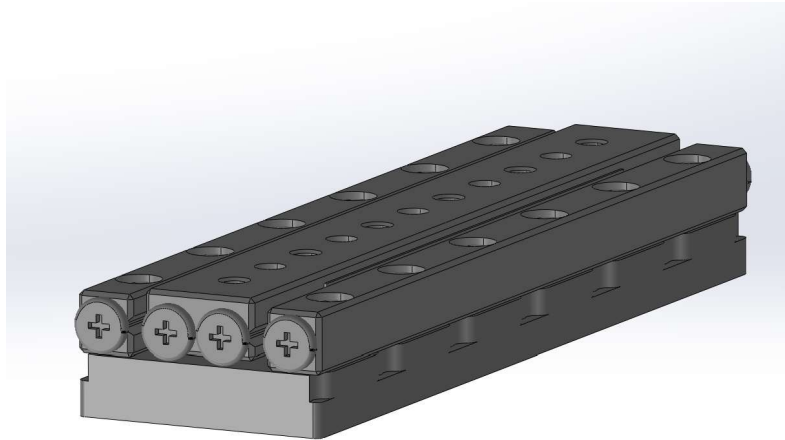

Linear actuator here is: SLC-1760 Linear Piezo Stage

- Mainly due to introducing the linear actuator.
- Needs time for ordering and delivering.
- Others all acquired

Dependencies

These are the dependencies related to the current progress.

	Current Status	Needed by	Effect
EPOS4	Obtained		
POC* prototype	Finished wait for testing		
Linear actuator	In Progress	03/31/2022	Delay in building the second prototype with left/right controlling logic
Wire for loop	Obtained	EP** by 03/31/2022	No preshaped wire: limited bending in up/down
Metal parts	Obtained for POC*	EP** by 03/31/2022	Delay in finishing prototype of Expected deliverable
Expected Prototype	In Progress	04/01/2022	Deley in starting preparing for the maximum deliverable

Update on Testing

- Gel ball can not provide structures of eye.
- Test of button-controlled prototype (expected model) can use pig eye.

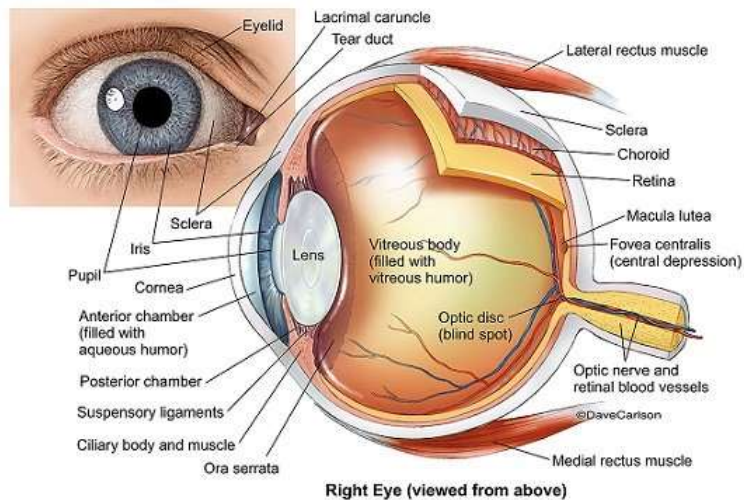

Fresh pig eye can provide:

1. Similar structure (Sclera, Choroid, & Retina)
2. Similar inner environment
3. Easy to obtain

Milestones

Milestones	Expected Date
POC prototype	03/25/2022
Expected prototype	04/15/2022
Maximum prototype	05/01/2022

Expected date of POC prototype will be added 10 more days to address the newly testing method mention above.

Updated Timeline

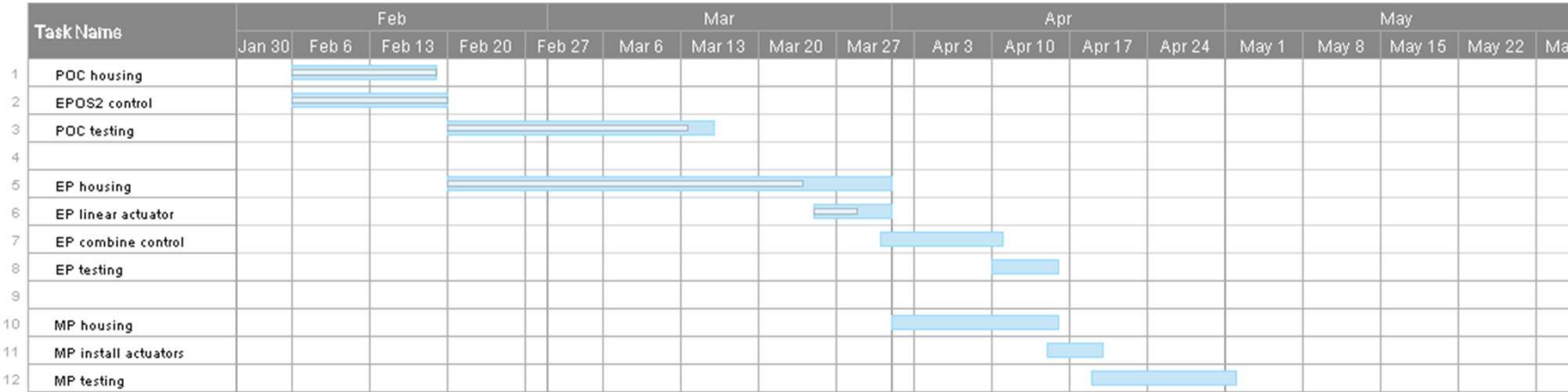

Thanks!
Questions?

