

Autonomous Suture Management

Team members: Nyeli Kratz, Jiawei Liu, Nathan Van Damme

Mentors: Michael Kam, Dr. Axel Krieger

Table of Contents

- Introduction
 - Background
 - Goals and Significance
- Technical Approach
 - Overview
 - Mechanical Design of Large-Scale Prototype
 - Mechanical Design of Small-Scale Prototype
 - Control System/STAR Interface
 - Testing Plan
- Management Plan
 - Deliverables
 - Dependencies
 - Timeline
 - Milestones
 - Responsibilities
- References
- Reading List

Introduction

Background:

Increasing the level of autonomy in surgical robotic systems, particularly for time-consuming and repetitive tasks such as suturing, can help to standardize patient outcomes and free up surgeons to complete other tasks. Anastomosis (see figure 1) is a surgical procedure in which a luminal structure is reconstructed. It requires a high degree of maneuverability and repeatability and is thus a good candidate for examining autonomous robotic surgery on soft tissue [5].

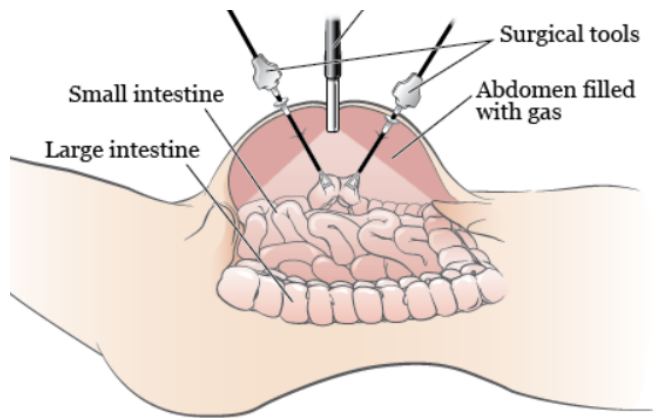

Figure 1. Diagram of manual laparoscopic anastomosis [1]

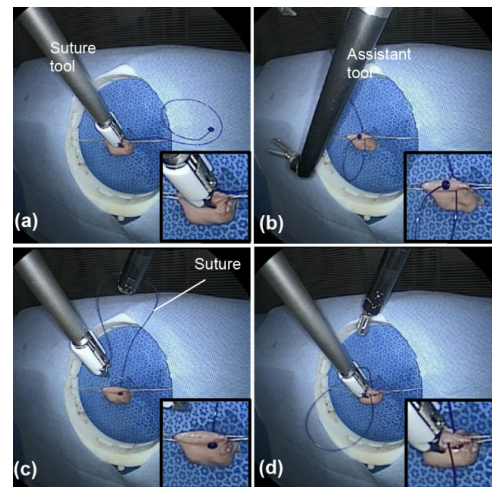

Figure 2. Endo360 with STAR autonomous suturing [2]

The Endo360 with Smart Tissue Autonomous Robot (STAR) performs autonomous suturing in laparoscopic anastomoses. STAR has been shown to increase the consistency of suturing compared to both traditional manual surgery and non-autonomous robotic surgery [3]. However, because STAR requires human assistance for suture tensioning management (see figures 2 and 3), STAR requires two incision sites to accommodate both laparoscopic arms, one for autonomously placing the sutures and one which is controlled by a human to manage the tensioning. Additionally, the need for human assistance in suture tensioning management means that STAR is not fully autonomous, creating a task which the surgeon must perform manually.

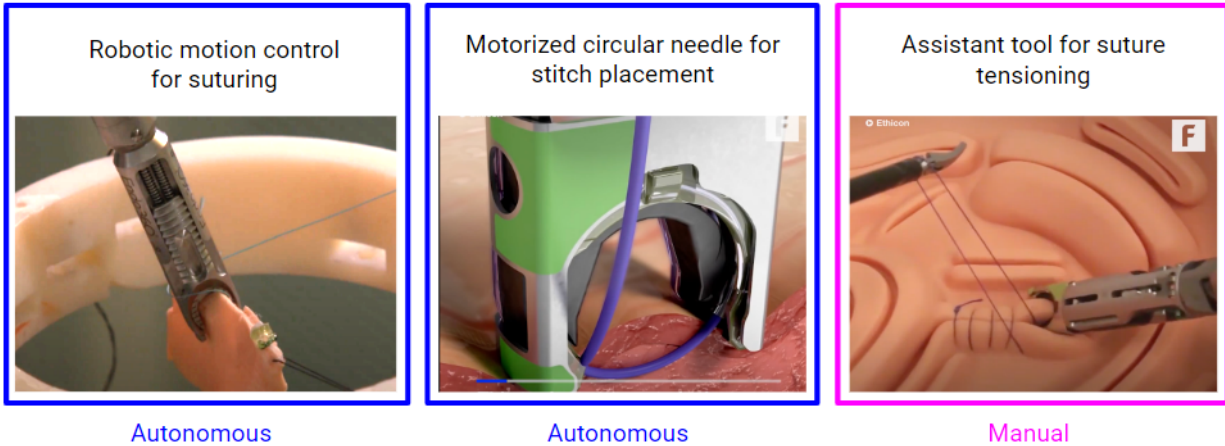

Figure 3. STAR current autonomous suturing workflow. Robot motion control and stitch placement is currently fully autonomous, but the assistant tool for suture tensioning management is controlled manually.

Goals and Significance:

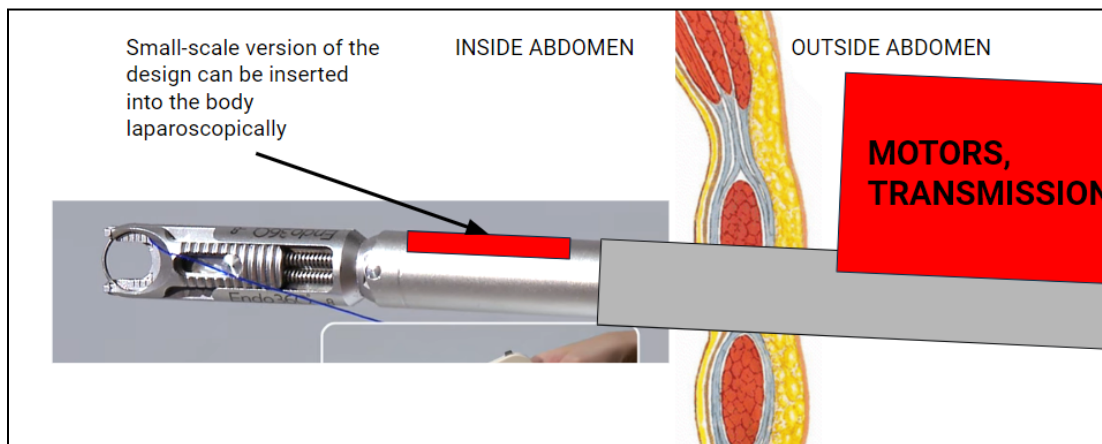

Figure 3. Diagram of project goal: small-scale mechanism which attaches to the Endo360 with STAR and can be inserted into the abdomen laparoscopically.

The goal of this project is to develop an autonomous mechanism which enables STAR to perform single-arm robotic suture management and tensioning. This mechanism will replace the need for manual tensioning management and thus increase the level of autonomy of STAR. This will decrease the workload of the surgeon and also decrease the invasiveness of STAR procedures, since only one incision site would be needed as opposed to the two which are needed for the current dual-arm approach.

Our mechanism must be capable of fitting inside of a 25mm diameter hole [4] for single-port laparoscopic surgery and must autonomously complete the tasks currently done by the manual assistant of catching, tensioning, and releasing the thread after STAR completes a stitch.

Technical Approach

Overview

Below we have outlined an overview of the tasks necessary in suture tensioning management. Our mechanism must be able to accomplish each of these tasks autonomously. We have included a design task which will be implemented into our mechanism to complete the given step of the workflow.

Workflow of suture management:

1. Catch the thread after a stitch is placed by STAR.
 - a. Design a mechanism (e.g. gripper) to grasp the suture.
2. Tension the suture.
 - a. Design a mechanism to apply tension to the thread via motors.
3. Stop suture tensioning.
 - a. Detect the completion of suture tension and stop the process.
4. Release the thread.
 - a. Release the suture from the mechanism to allow STAR to place the next stitch.

Our technical approach for this project is to first design and test a large-scale prototype for autonomous suturing outside of the body before moving forwards with the design of a small-scale prototype based on what we have learned from the initial prototyping.

Mechanical Design of Large-Scale Prototype

For our first round of prototype development, we are creating a large-scale prototype which attaches to the arm of the KUKA robot. The purpose of this prototype is to test a mechanism which we plan to further miniaturize so that it is useful in laparoscopic surgeries. We will test the functionality of this prototype outside of the body and this will dictate how we move forward with our small-scale prototype.

Our large-scale prototype is mounted on the 7-DOF KUKA lightweight arm attached to the STAR and consists of two components: a swing mechanism at the front and a suture-tensioning rotor in the midsection. The “swing mechanism” catches the thread after the Endo360 completes a stitch and brings the thread to the midsection reel for tensioning.

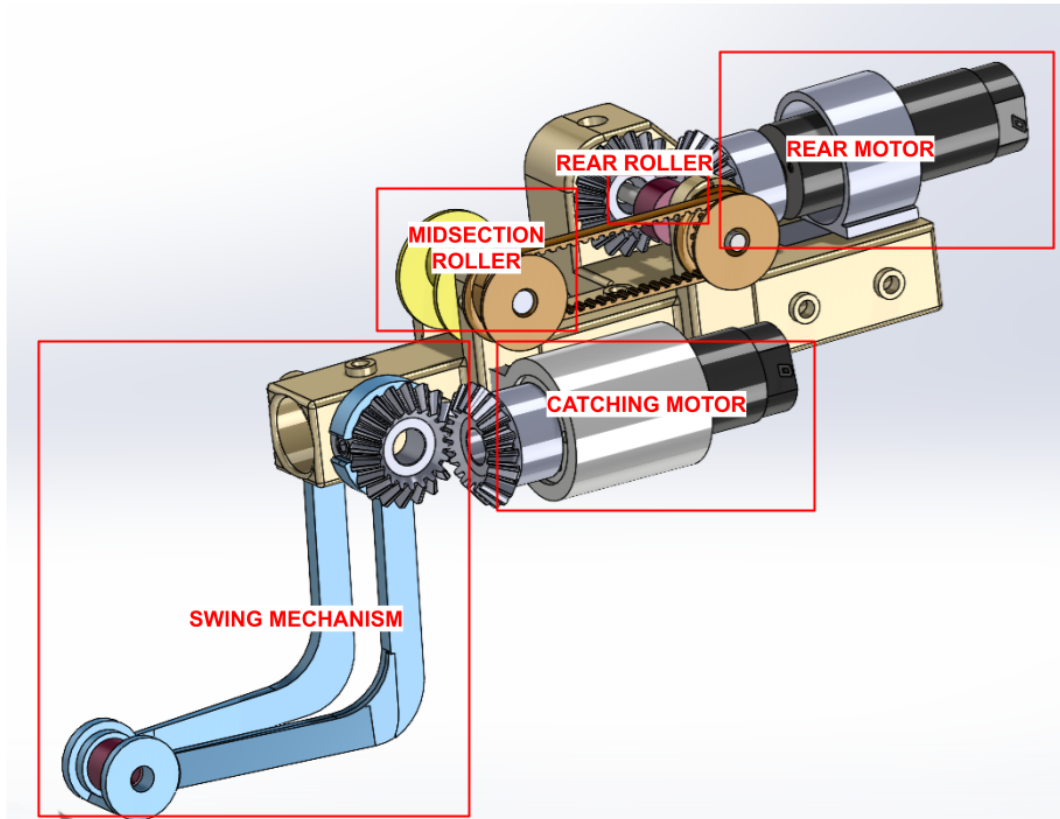

Figure 4. Large-Scale Prototype CAD model with labeled components

a) Swing Mechanism (see figure 4)

The “swing mechanism” catches the thread after the Endo360 completes a suture and brings the thread to the midsection reel for tensioning. The tip of the STAR is retrofit by a commercially-available manual laparoscopic suturing tool, Endo360. The Endo360 has 1-degree of freedom and uses a motorized circular needle to place sutures. As the stitching is a periodic movement, sutures can always be caught by the same side of the tip's caliper. The swing mechanism has a free-spinning rubber wheel, which is used to grasp the thread after the Endo360 completes a stitch. The swing mechanism catches the thread on its rubber wheel and then brings the thread to a rear roller, allowing the midsection reel to catch the thread.

b) Midsection roller (see figure 4)

The midsection reel tensions the thread, which is driven by the rear motor through a belt pulley. The reel is designed with a curved hook which points in the rotation direction, allowing the reel to catch and tension the thread without tangling. When the suture is adequately tensioned, the rear motor will detect an increase in torque. This will tell the motor to stop and then start spinning in the opposite direction to release the thread.

Mechanical Design of Small-Scale Prototype

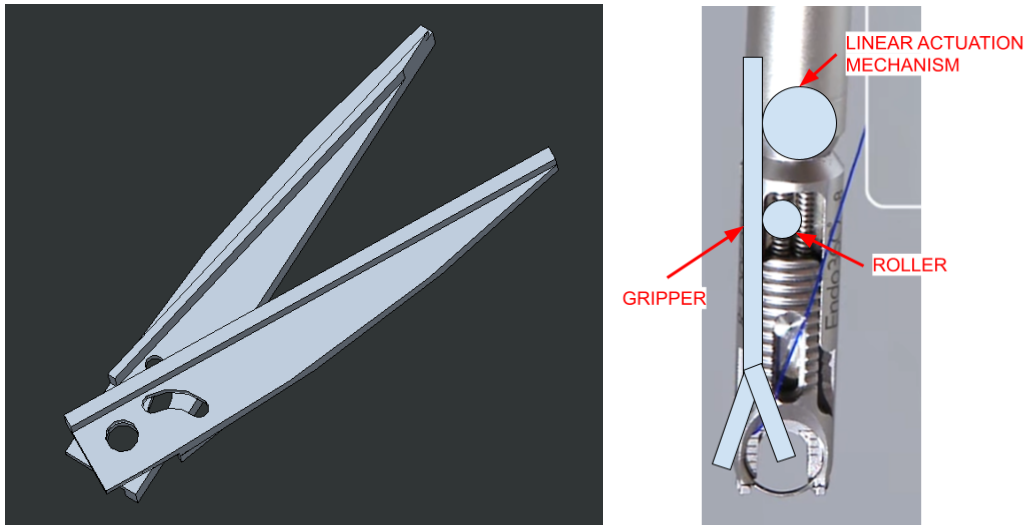

Figure 5. CAD model of gripper mechanism (left) and diagram of current design for small-scale prototype (right)

The small-scale version of this design will utilize a cable-driven gripper to grasp the thread after the STAR finishes a suture as shown in figure 5. This gripper will be mounted on a small linear actuation mechanism which will allow it to move out to catch the thread after the Endo360 completes a stitch while maintaining a small footprint, thus allowing the device to fit inside of a 25mm diameter hole. This prototype will maintain a scaled-down version of the “midsection roller” on the large-scale prototype for suture tensioning and will otherwise function in a similar manner to the large-scale prototype. This design is subject to change as we learn more through prototyping and testing.

Control System/STAR Interface

Our mechanism is controlled and served by the rear-motor and catching motor (figure 4), which are operated by ROS via CAN system. Based on the position-model control, the motor could drive the swing mechanism to bring the suture thread to a specific place to tension it. For torque-model control, the motor could precisely detect whether the suture thread has already been tensioned. By communicating via the CAN system, ROS could control every motion and cooperate with the whole device with STAR robot so as to realize autonomous suturing operations.

Testing Plan

We will implement testing to ensure that our prototype can successfully replace the role of manual suture tensioning assistance currently utilized by the STAR system. Therefore, testing will consist of 2 phases: phase 1 mainly checks prototype functionality while phase 2 evaluates the performance of our device in comparison to the current dual-arm suturing approach.

During the first phase of testing, we will test the performance of each step of the autonomous suturing workflow process which we have described in the overview section.

1. Catch the thread: In this step, we want to ensure that our device can consistently capture the thread to perform the next suture. For this reason, the catching accuracy will be assessed as a measure of the number of successful catches in 100 attempts.
2. Tension the suture: An important aspect of the quality of a suture is the cable tension. As a reference for adequate suturing, a force of 1N cable tension is regarded as sufficient [5]. We plan to measure the force by attaching a force sensor to the suture cable and fixating it. Additionally, we measure the time required to tension the thread which can then be compared to literature [2].
3. Stop suture tensioning: the stopping criteria for the tensioning is the force exerted on the suture. A force of 5N should be satisfactory and can easily be measured by analyzing the corresponding motor torque [2].
4. Release the thread: Releasing accuracy will be assessed as a measure of the number of successful releases in 100 attempts.

Note that these four steps occur in both the large- and small-scale prototype. This allows us to compare the performance of the prototypes against one another. This testing is an important part of prototyping since it will provide valuable information about current design flaws.

The second testing phase focuses on the small-scale device and how its performance compares to the current STAR autonomous suturing workflow with the dual-arm setup. First, we want to use the CAD model of the small-scale prototype to analyze the workspace that the prototype occupies in a Solidworks motion analysis. This will be compared to the workspace of the dual-arm approach as a measure of the invasiveness of our device.

Following this, physical testing of the small-scale prototype will be performed. To simulate a suture in the human body, the physical prototype will be mounted onto a pre-existing test setup where it will suture synthetic skin. This allows us to analyze commonly used metrics in literature. Firstly, the total stitch time and number of failed sutures can now be measured more accurately since a full stitch procedure is performed. On top of that, the setup allows us to

analyze the bite depth. This is important to check how consistent the device sutures and and can be expressed numerically by looking at the coefficient of variance [3].

Management Plan

Deliverables

1. **Minimum:** (Expected by 3/7/2023)
 - a. Large-scale prototype demonstrating mechanism that is made of 3D printed materials and off-the-shelf parts and controlled by Arduino.
 - b. Test results with large-scale prototype indicating that the prototype is able to catch thread, tension, and release thread on the Endo360 with STAR robot outside of the body.
2. **Expected:** (Expected by 4/30/2023)
 - a. CAD model of small-scale prototype (can be inserted into the abdominal cavity laparoscopically in a 25mm diameter hole).
 - b. Large-scale prototype which can be controlled via CANbus.
 - c. Test results of large-scale prototype against current dual-arm approach of the Endo360 with STAR.
 - d. Test results of CAD model of small-scale prototype indicating that the prototype is able to catch thread, tension, and release thread and also indicating prototype workspace.
3. **Maximum:** (Expected by 5/15/2023)
 - a. Small-scale physical prototype (can be inserted into the abdominal cavity laparoscopically in a 25mm diameter hole) works with the Endo360 with STAR robot. The prototype must be able to catch thread, tension, and release thread on the Endo360 with STAR robot inside of the human abdomen.
 - b. Test results of small-scale prototype against current dual-arm approach of the Endo360 with STAR robot.
 - c. Conference publication.

Dependencies

Dependency	Need	Status	Follow-up	Contingency	Deadline
Existing device	Preliminary research	Acquired - assembled	N/A	N/A	2/15/2023
Solidworks CAD	Design	Acquired	N/A	Use Creo	2/15/2023

software				parametric	
3D printers	Prototyping	Acquired - BME Design studio	N/A	Get training to use Wyman 3D printers	2/15/2023
Off-the-shelf hardware (motors, encoders, etc.)	Prototyping	Dr. Krieger's lab will fund this; and we will order parts when design is finalized (see timeline)	Mentor Michael Kam will help us.	N/A	4/10/2023
Synthetic skin + testing setup	Testing	Acquired - in Dr. Krieger's lab	N/A	N/A	4/10/2023
CANbus control system	Control	Acquired - made by Michael Kam	N/A	Arduino-based control	4/10/2023

Table 1: Overview of dependencies. Dependencies in green have been acquired, dependencies in yellow have yet to be acquired.

The project relies on several dependencies, both hardware and software, which have been listed in Table 1. As can be seen, the necessary software is installed and the majority of the hardware has already been acquired including the existing large device, the synthetic skin setup and a 3D printer. However, several other components will have to be ordered as the project evolves since the small-scale design is not final yet. These will most likely include off-the-shelf hardware like motors, cables, belts, etc. Hardware will preferably be ordered from McMaster-Carr which has an ordering time of less than a week and funding will be provided by the lab. Since our goal is to have a physical prototype by the 10th of April, the components will have to be ordered ahead of time, as soon as the team agrees on a design concept making the ultimate deadline 3th of April. Some parts will likely be ordered earlier during development when individual tests described in testing phase 1 will be performed. Again, care will be taken with respect to delivery times.

Timeline

	February				March				April				May			
Preliminary research and brainstorming																
Literature review																
Assess functionality of current design																
Brainstorming																
Choose a design concept to move forward with																
Design																
CAD modeling																
Prototyping																
Order parts																
Fully assemble prototype																
Control																
Mount into test setup																
Implement control method																
Test performance of prototype vs. dual-arm approach																
Final Report																

Table 2: Timeline with week by week overview. Different colors depict different stages of the project. DR 1 & 2 represent full-team design reviews.

Milestones

1. Milestone name: Physical large-scale prototype
 - Planned Date: 2/21/2023
 - Expected Date: 3/1/2023
 - Status: in progress
2. Milestone name: Test results of large-scale prototype
 - Planned Date: 3/1/2023
 - Expected Date: 3/10/2023
 - Status: not started
3. Milestone name: CAD model of small-scale prototype (can fit in 25mm diameter hole)
 - Planned Date: 3/5/2023
 - Expected Date: 3/15/2023
 - Status: not started

4. Milestone name: Test results of small-scale prototype CAD model
 - Planned Date: 3/21/2023
 - Expected Date: 3/30/2023
 - Status: not started
5. Milestone name: Physical small-scale prototype (can fit in 25mm diameter hole)
 - Planned Date: 4/1/2023
 - Expected Date: 4/5/2023
 - Status: not started
6. Milestone name: Test results of physical small-scale prototype
 - Planned Date: 4/12/2023
 - Expected Date: 4/30/2023
 - Status: not started

Responsibilities

Nyeli

- Mechanical design of small-scale prototype.
- 3D printing, machining, assembly, documentation.

Jiawei

- Mechanical design of large-scale prototype.
- CANbus control of large-scale prototype.
- 3D printing, machining, assembly, documentation.

Nathan

- Physical testing design and Solidworks simulations testing design.
- 3D printing, machining, assembly, documentation.

Responsibilities Interface: All team members will collectively work together on early-stage mechanical design concept brainstorming as well as physical prototyping. Nyeli and Jiawei will hand off completed physical prototypes to Nathan for physical testing and will hand off completed CAD models to Nathan for SolidWorks simulations testing.

References

1. "Diagnostic Laparoscopy." *Memorial Sloan Kettering Cancer Center*, 21 May 2019, <https://www.mskcc.org/cancer-care/patient-education/laparoscopy>
2. Leonard, S., Opfermann, J., Uebele, N., Carroll, L., Walter, R., Bayne, C., Ge, J., & Krieger, A. (2021). Vaginal Cuff Closure With Dual-Arm Robot and Near-Infrared Fluorescent Sutures. *IEEE Transactions on Medical Robotics and Bionics*, 3(3), 762–772. <https://doi.org/10.1109/tmrb.2021.3097415>
3. Saeidi, H., Opfermann, J. D., Kam, M., Wei, S., Leonard, S., Hsieh, M. H., Kang, J. U., & Krieger, A. (2022). Autonomous robotic laparoscopic surgery for intestinal anastomosis. *Science Robotics*, 7(62). <https://doi.org/10.1126/scirobotics.abj2908>
4. Tsai, A. Y., & Selzer, D. J. (2010). Single-port laparoscopic surgery. *Advances in Surgery*, 44(1), 1–27. <https://doi.org/10.1016/j.yasu.2010.05.017>
5. Shademan, A., Decker, R. S., Opfermann, J. D., Leonard, S., Krieger, A., & Kim, P. C. W. (2016). Supervised autonomous robotic soft tissue surgery. *Science Translational Medicine*, 8(337). <https://doi.org/10.1126/scitranslmed.aad9398>

Reading list

1. Leonard, S., Shademan, A., Kim, Y., Krieger, A., & Kim, P. C. W. (2014). Smart Tissue Anastomosis Robot (STAR): Accuracy evaluation for supervisory suturing using near-infrared fluorescent markers. *Proceedings - IEEE International Conference on Robotics and Automation*, 1889–1894. <https://doi.org/10.1109/ICRA.2014.6907108>
2. Mosafer Khorjastan, S., & Rouhi, G. (2019). An Automatic Suturing Machine for Intestinal Anastomosis: Advantages Compared With Hand-Suturing Technique. *Surgical Innovation*, 26(2), 209–218. <https://doi.org/10.1177/1553350618808007>
3. Aksakal, O. S., Özyer, S. Sen, Güngör, T., Doğanay, M., Bilge, Ü., & Mollamahmutoğlu, L. (2007). Comparison of a new technique with deschamps ligature carrier for sacrospinous ligament fixation. *Archives of Gynecology and Obstetrics*, 276(6), 591–594. <https://doi.org/10.1007/s00404-007-0377-6>
4. Doğanay, M., & Aksakal, O. (2013). Minimally invasive sacrospinous ligament suspension: Perioperative morbidity and review of the literature. *Archives of Gynecology and Obstetrics*, 287(6), 1167–1172. <https://doi.org/10.1007/s00404-012-2687-6>
5. Phan, P. T., Hoang, T. T., Thai, M. T., Low, H., Davies, J., Lovell, N. H., & Do, T. N. (2021). Smart surgical sutures using soft artificial muscles. *Scientific Reports*, 11(1), 1–16. <https://doi.org/10.1038/s41598-021-01910-2>