

# Automation of Mosquito Dissection for Malaria Vaccine Production

## Design Concept of Rotary Stage

Group 1: Alexander Cohen, Henry Phalen, Michael Pozin

Mentors: Dr. Iulian Iordachita, Dr. Russell Taylor

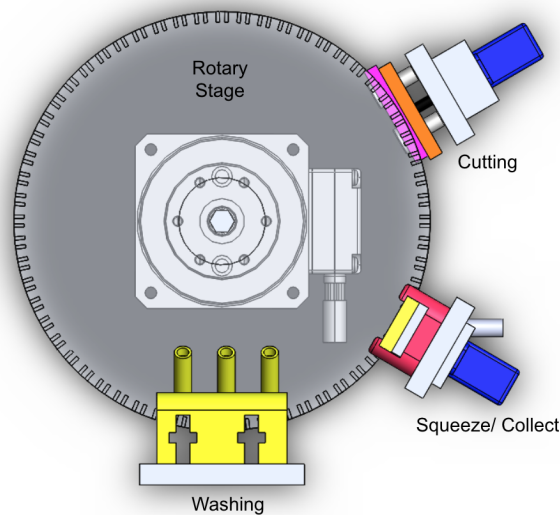

The overall goal of our project is to automate the dissection of glands from mosquitoes to streamline the processing of a malaria vaccine for Sanaria. The reason we decided to design a rotary stage when we already have a linear stage is to further optimize our solution. Currently we have a linear stage with three subsystems (cutting, squeezing / gland collection, and washing).

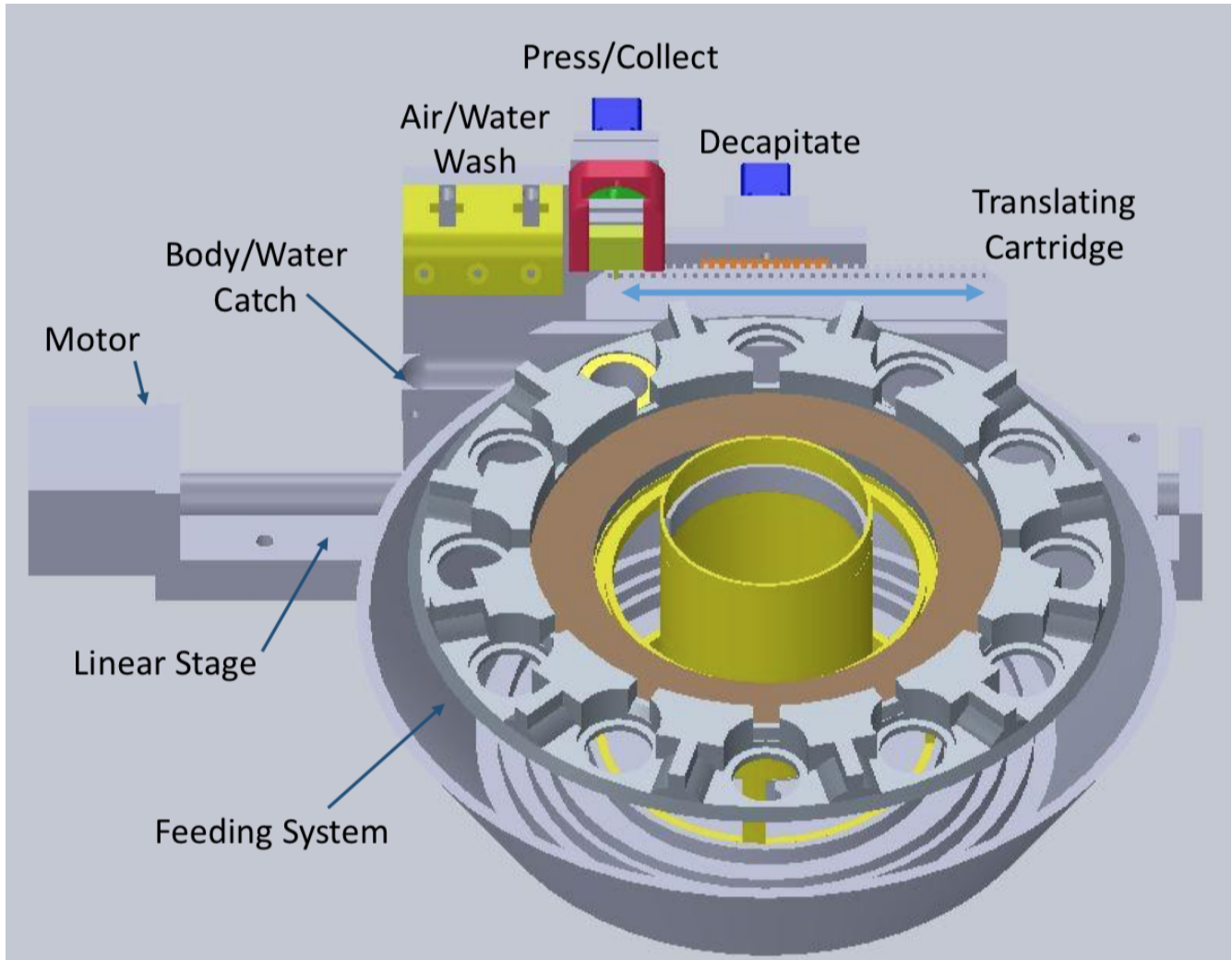

Figure 1. The Linear stage design currently being used to process mosquitoes with its subsystems and the feeding system used to present mosquitoes to the robot to place on the cartridge.

The issue with this system is that it is not continuous, once the cartridge holding the mosquitoes reaches the end of the linear stage it has to return to its home position wasting valuable time not processing mosquitoes. The obvious solution is to take the existing subsystems which are developed on the linear stage model and transplant them seamlessly onto a continuous rotary design. This allows for continued testing of our subsystems and the downstream dissection process without major design changes to the existing setup. Which allows for tuning of the subsystems without needing to integrate the rotary stage which will likely take weeks to construct and test.

There were two obvious design avenues for the rotary stage approach; the **Concentric Rotary Stage**, and the **Tangential Rotary Stage** (see Figure 2). The concentric design, which is designed to exist as the concentric outer ring of the system with mosquito feeder at the interior. This design was terminated early due to the scope of the project, with the issue that the concentric system was so dependant on other teams design choices. Given the time to do this project and the number of different components being designed for the system it did not seem reasonable to try to design around a constantly changing feeding system and its associated subsystems. However in the future the concentric design does offer benefits over the tangential design, in that it can be more compact and could possibly have two processing systems for a single feeder (Figure 3).

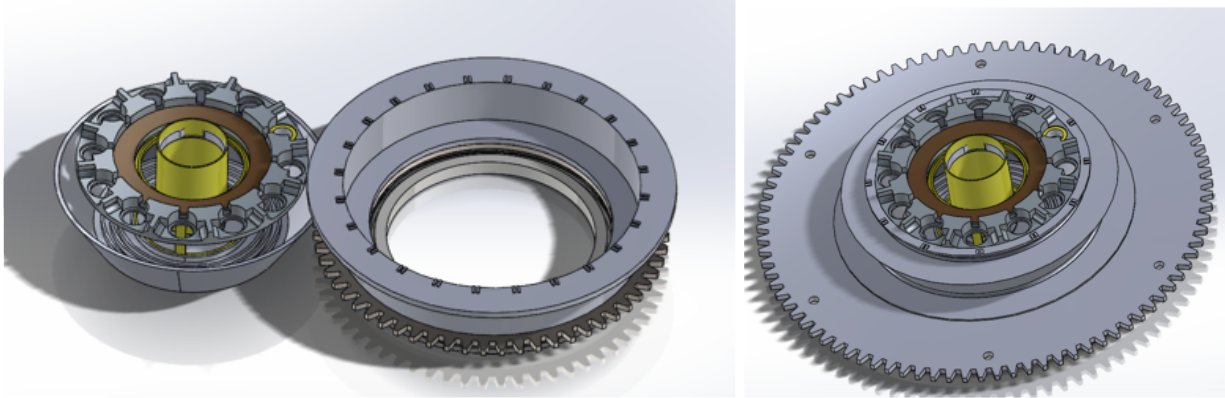

Figure 2. Initial concept designs for tangential (left) and concentric (right) rotary stages. These were conceptual designs that lead to a decision of pursuing the tangential design in favor of concentric.

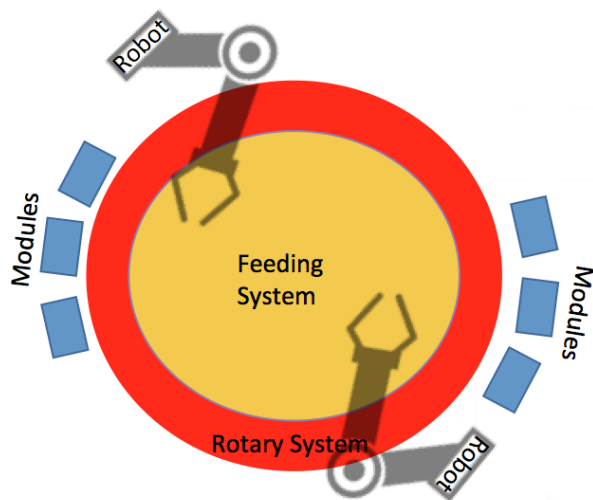

Figure 3. Rough idea of how the concrete design could utilize multiple robots for a single feeder and process multiple mosquitoes simultaneously.

The Tangential Rotary Stage design is what we currently have a more complete design review of. The current design utilizes the same subsystem currently being developed with the linear stage design (see Figure 4). This again is to streamline the process of integrating the new new design in the future when we have thoroughly developed method of extracting the processing the mosquitoes.

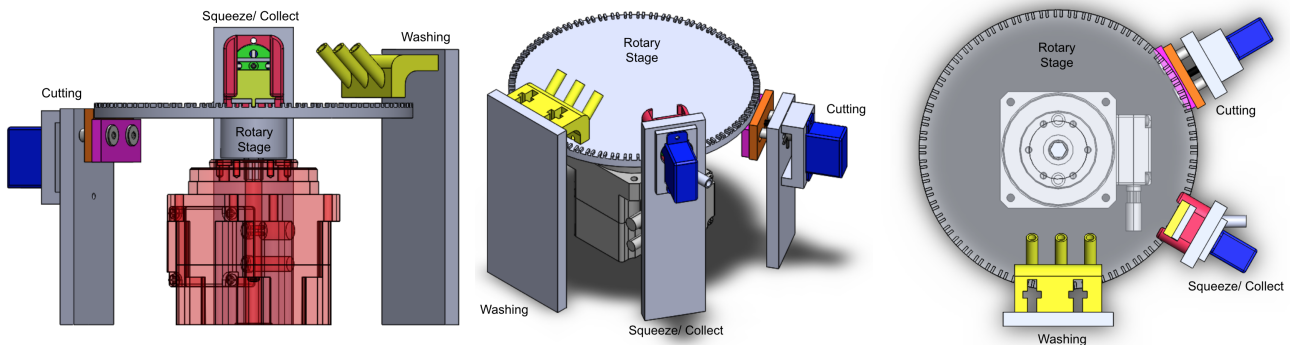

Figure 4. *Rough design of the three subsystem around the tangential rotary stage. Front view (left), Isometric view (middle), and top view (right). Rotation of stage is clockwise as viewed from the top view.*

A significant reason the design was chosen was do to how it can be integrated with the existing feeder system. Since the design is tangential it interacts in the same way the linear stage currently does with the feeder system. The linear system is something the other designers are familiar with and have already designed components with it in mind. The design is simple and has a relatively small footprint it easily integrates the existing subsystems since the stage is basically the same as the linear cartridge but wrapped into a circle (Figure 5). Since we want a high degree of precision in this system a harmonic drive is being used. This may not strictly be necessary but it is believed to only have added benefits. The diving motor is a simple stepper motor with a absolute encoder that should be easy to integrate with our existing setup since our linear design also uses a stepper motor, however a 24V power supply will be needed for this new motor. The harmonic gearbox will make our system a zero backlash system and having a homing mechanism design into the system will make a extremely robust and accurate system for locating the slots directly under the cutting and squeezing/gland collection subsystems. The stage is connected to the driver via a hex shaft which mates the two rigidly. For this design the current robot setup will not work. This design only works for a inverted robot design mounted above the work space. The robot will need to overhang the two systems and perform its pick and place operation from above. This requires a new robot to be designed but both the concentric and tangential systems have this same problem.

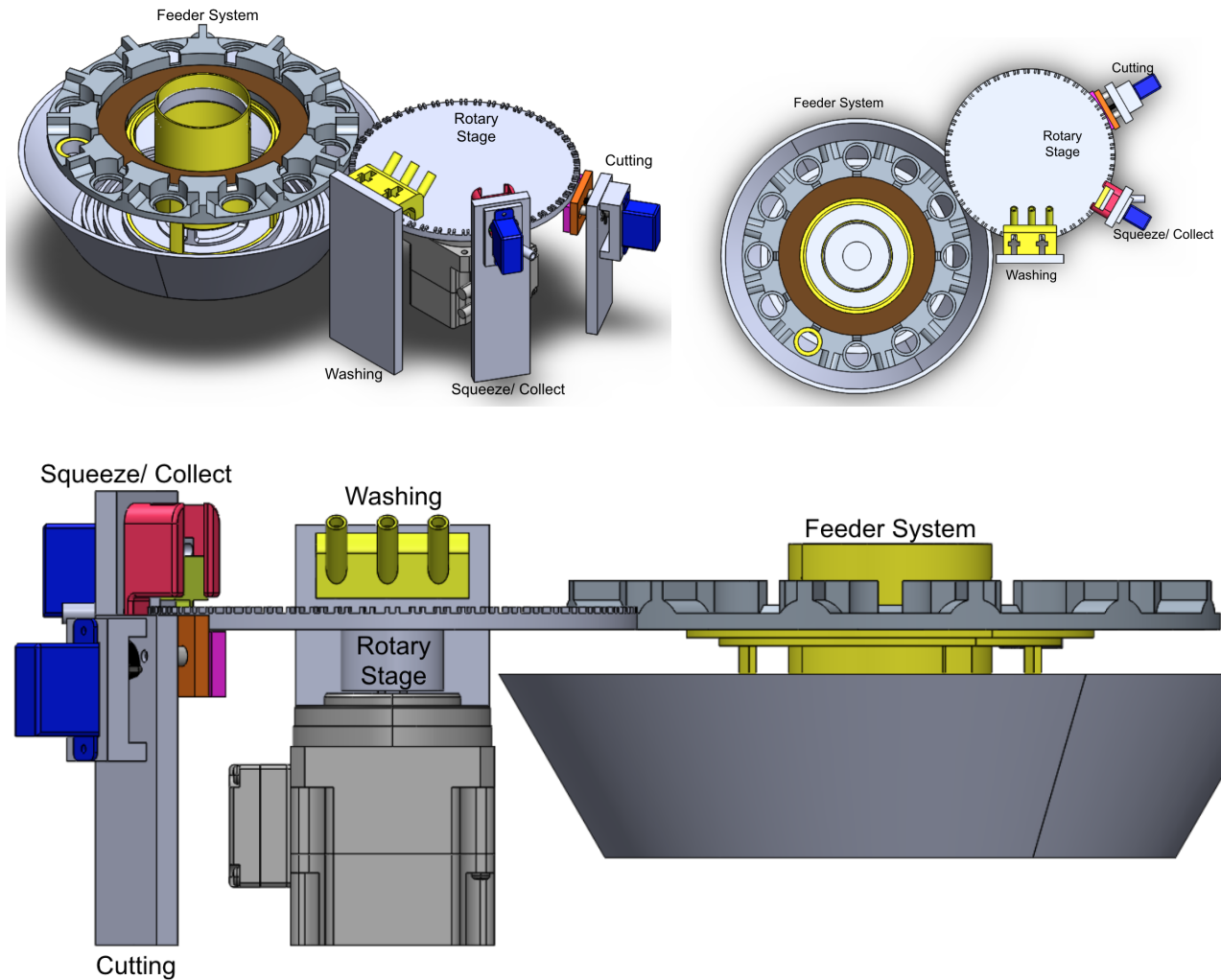

Figure 5. Possible mating of tangential rotary stage with existing feeder stage. This is just a suggested setup with the idea that the overhanging robot would not need to rotate after picking up the mosquito to place it but other configuration are possible where the cups are closer to the cutting mechanism. Isometric view (top right), top view (top left) and side view (bottom). Looking at the side view the feeder will need to be on a elevated stand but this is not seen as a significant problem which is simple to solve.

## Other Notes -

### Drive-Train Details:

Website: <http://www.harmonicdrive.net/products/rotary-actuators/hollow-shaft-actuators/fha-mini>

P/N: FHA-8 C-xx-12S17bE-C (where xx is 30, 50 or 100 specifying a reduction ratio of the Harmonic gear box of xx:1)

### Other design work:

There has also been work done on designing a new gripper actuation unit for grasping of mosquitoes. The original design is complex and has some tolerancing design issues. The goal was to take the general idea of the current system and simplify it. Currently the system uses a simple rotary servo motor and a cam to actuate along a linear slide. There are some tolerance issues that lead to rocking of components that need to remain straight. A precision slide was added to improve this problem but only did so much. The current plan is to use a linear actuator with PWM control similar to the servo motor and replace the servo and cam with this. The precision linear slide will remain in use to help constrain the system. There are significantly fewer components in this design which means less things to go wrong. There are two blocks: one for holding the outer sleeve of the gripper and the other to hold the inner tube with the tweezer end. The gripper block is mounted on the linear slide and attached to the linear actuator and is what actuates the tweezer end of the gripper. The design is not yet finalized but is near completion. It will be designed to be machinable so that it can be manufactured out of stiff materials easily. It is also designed with the user in mind making it easy to replace broken gripper components and install them more easily and with greater accuracy. It also will fix issues with the tweezer end not having enough clearance due to certain design issues with the original design.

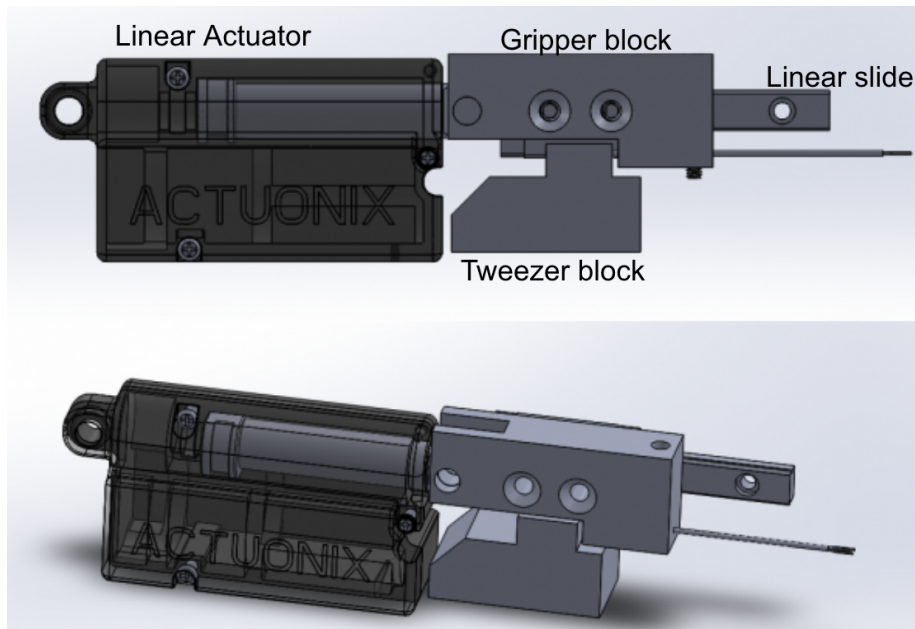

Figure 6. Version 1 of new gripper design.